

IT ATTENZIONE:

LA SICUREZZA DELL'APPARECCHIO E' GARANTITA SOLO CON L'USO APPROPRIATO DELLE SEGUENTI ISTRUZIONI; PERTANTO E' NECESSARIO CONSERVARLE.

EN WARNING:

THE SAFETY OF THIS FIXTURE IS GUARANTEED ONLY IF YOU COMPLY WITH THESE INSTRUCTIONS; REMEMBER TO CONSERVE IN A SAFE PLACE.

FR ATTENTION:

LA SECURITE DE L'APPAREIL N'EST GARANTIE QU'EN CAS D'UTILISATION CORRECTE DES INSTRUCTIONS SUIVANTES; IL FAUT PAR CONSEQUENT LES CONSERVER.

DE ACHTUNG:

DIE SICHERHEIT DES GERÄTES WIRD NUR DURCH SACHGEMÄSSE BEFOLGUNG NACHSTEHENDER ANWEISUNGEN GEWÄHRLEISTET; IHRE AUFBEWAHRUNG IST DESHALB SEHR WICHTIG.

NL OPGELET:

DE VEILIGHEID VAN DI ATOESTEL IS SLECHTS DAN GEGARANDEERD ALS INDIEN DE VOLGENDE INSTRUCTIES STRIKT WORDEN TOEGEPAST; DAAROM MOET MEN ZE OOK BEWAREN.

ES ATENCION:

LA SEGURIDAD DEL APARATO SE GARANTIZA SOLO CUMPLIENDO CUIDADOSAMENTE LAS SIGUIENTES INSTRUCCIONES; POR ELLO, ES NECESARIO CONSERVARLAS.

DA BEMÆRK:

SIKKERHEDEN VED BRUG AF ARMATURET KAN KUN GARANTERES, HVIS DISSE ANVISNINGER FØLGES; SØRG DERFOR FOR AT GEMME DEM.

NO ADVARSEL:

SIKKERHETEN TIL DETTE APPARATET GARANTERES KUN HVIS DU OVERHOLDER DISSE INSTRUKSJONENE; HUSK Å OPPBEVARE DEM PÅ ET TRYGT STED.

SV OBSERVERA!

UTRUSTNINGENS SÄKERHET KAN ENDAST GARANTERAS OM DESSA ANVISNINGAR RESPEKTERAS I DETALJ. SPARA DÄRFÖR DESSA ANVISNINGAR FÖR FRAMTIDA KONSULTATION.

RU ВНИМАНИЕ:

МЫ ГАРАНТИРУЕМ БЕЗОПАСНУЮ ЭКСПЛУАТАЦИЮ ИЗДЕЛИЯ ТОЛЬКО ПРИ СОБЛЮДЕНИИ СЛЕДУЮЩИХ ИНСТРУКЦИЙ; С ЭТОЙ ЦЕЛЬЮ НЕОБХОДИМО СОХРАНИТЬ ДАННУЮ БРОШЮРУ.

ZH 警告

为确保该装置安全，请遵守操作指示；并于安全场所放置。

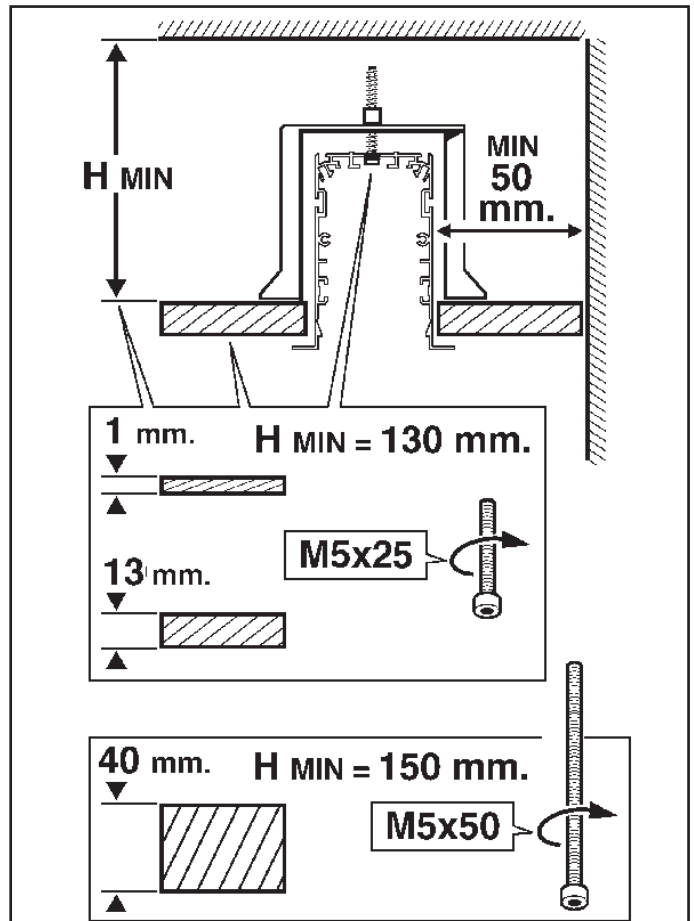
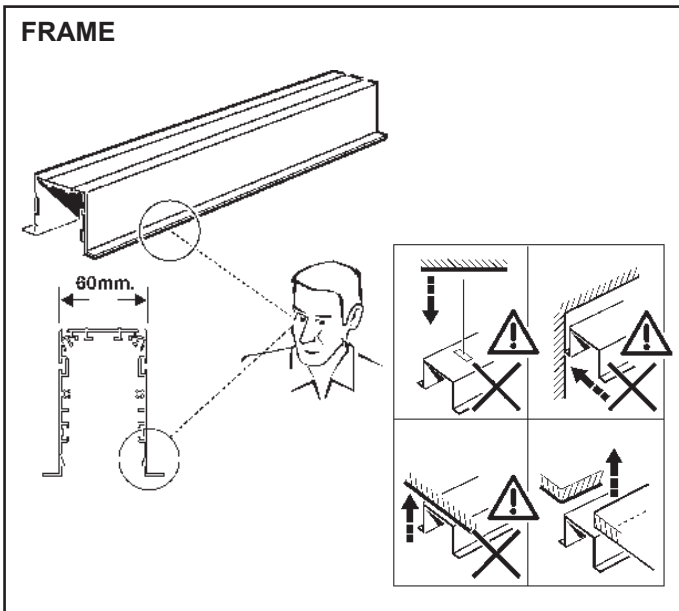
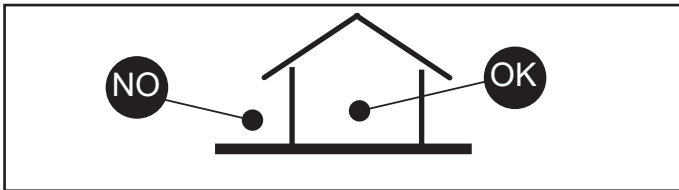

OPENING CALCULATION

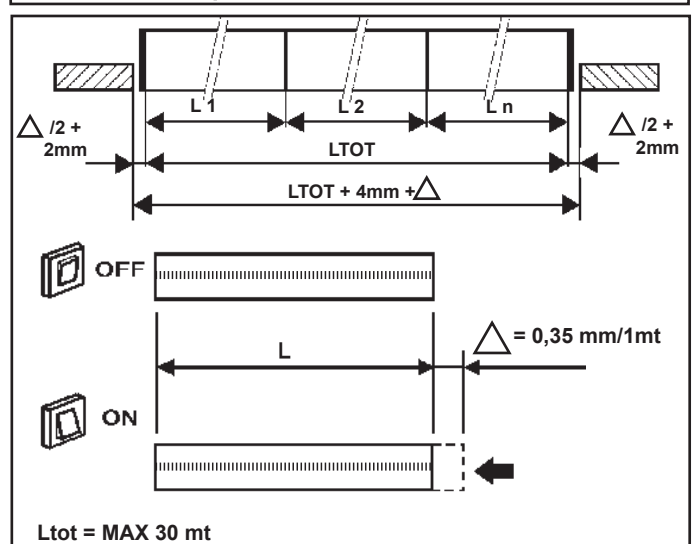
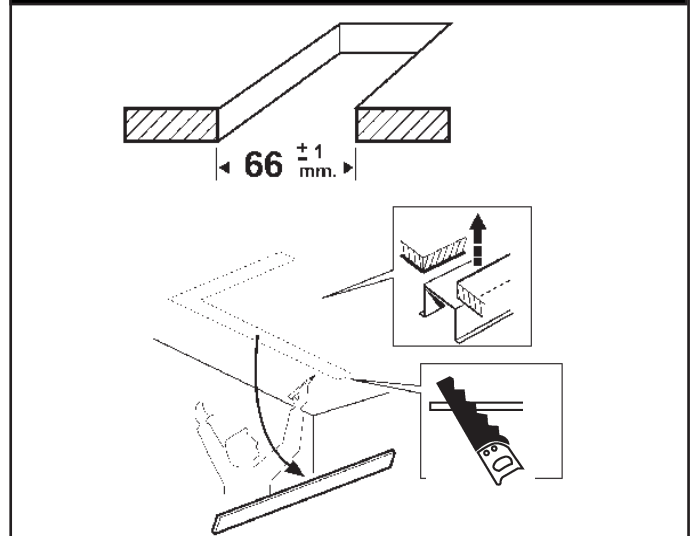

PRODUCT DIMENSIONS

ART.	L (mm)
QA84 - QB64 - QZ63 - QZ91	612
QA85 - QB65 - QZ64 - QZ92	1208
QA86 - QB66 - QZ65 - QZ93	2397
QA87 - QB67 - QZ66 - QZ94	3596
QA88 - QB68 - QZ67 - QZ95	898
QA89 - QB69 - QZ68 - QZ96	3596
QX47	1192
QX54	2384



ART.	L (mm)
QB00 - QB01 - QB02 - QB03 QB32 - QB33 - QB34 - QB35 QB80 - QB81 - QB82 - QB83 QZ77 - QZ79 - QZ78 - QZ80 QZ81 - QZ83 - QZ82 - QZ84 R051 - R053 - R052 - R054	642 x 642

Non serrare a fondo
Do not tighten fully
Ne pas serrer à fond
Nicht vollständig festziehen
Niet geheel vast draaien
No atornille a fondo
Skrú ikkje helt i bund
Ikke trekk helt til
Dra inte át till botten
Не закручивать до упора
请勿完全拧紧

**ACCESSORY
END CUP
ART. PB32 - MWP7**

Serrare a fondo
Tighten firmly
Serrer à fond
Fest einrasten
Goed aanschroeven
Enrosar en firme
Skrues i bund
Trek til godt
Dra át till botten
закручивать до упора
完全拧紧

IT Per le posizioni di installazione, attenersi a quelle illustrate, eventualmente contattare la iGuzzini.

EN All installation positions must comply with those illustrated. In the event of any doubt, contact iGuzzini.

FR Pour les positions d'installation, se conformer aux positions illustrées ; contacter la société iGuzzini en cas de nécessité

DE Für die Einbaupositionen die Abbildungen beachten. Eventuell iGuzzini kontaktieren.

NL Houd u voor de installatieposities aan degene die zijn weergegeven. Neem eventueel contact op met iGuzzini

ES Respetar las posiciones de instalación ilustradas y, en caso de duda, contactar con iGuzzini

DA For installationspositioner skal man holde sig til de viste, og eventuelt kontakte iGuzzini

NO For installasjonsplasseringene henviser vi til illustrasjonene, eller ta eventuelt kontakt med iGuzzini

SV Följ de angivna positionerna för installationen. Kontakta vid behov iGuzzini

RU При выборе положения для монтажа следует обратиться к проиллюстрированным либо обратиться в компанию iGuzzini

ZH 安装位置请参考图示，必要时也可联系iGuzzini

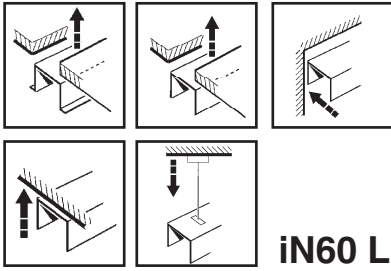

IN60 LED

IT ATTENZIONE:

LA SICUREZZA DELL'APPARECCHIO E' GARANTITA SOLO CON L'USO APPROPRIATO DELLE SEGUENTI ISTRUZIONI; PERTANTO E' NECESSARIO CONSERVARLE.

EN WARNING:

THE SAFETY OF THIS FIXTURE IS GUARANTEED ONLY IF YOU COMPLY WITH THESE INSTRUCTIONS; REMEMBER TO CONSERVE IN A SAFE PLACE.

FR ATTENTION:

LA SECURITE DE L'APPAREIL N'EST GARANTIE QU'EN CAS D'UTILISATION CORRECTE DES INSTRUCTIONS SUIVANTES; IL FAUT PAR CONSEQUENT LES CONSERVER.

DE ACHTUNG:

DIE SICHERHEIT DES GERÄTES WIRD NUR DURCH SACHGEMÄSSE BEFOLGUNG NACHSTEHENDER ANWEISUNGEN GEWÄHRLEISTET; IHRE AUFBEWAHRUNG IST DESHALB SEHR WICHTIG.

NL OPGELET:

DE VEILIGHEID VAN DI ATOESTEL IS SLECHTS DAN GEGARANDEERD ALS INDIEN DE VOLGENDE INSTRUCTIES STRIKT WORDEN TOEGEPAST: DAAROM MOET MEN ZE OOK BEWAREN.

ES ATENCION:

LA SEGURIDAD DEL APARATO SE GARANTIZA SOLO CUMPLIENDO CUIDADOSAMENTE LAS SIGUIENTES INSTRUCCIONES; POR ELLO, ES NECESARIO CONSERVARLAS.

DA BEMÆRK:

SIKKERHEDEN VED BRUG AF ARMATURET KAN KUN GARANTERES, HVIS DISSE ANVISNINGER FØLGES; SØRG DERFOR FOR AT GEMME DEM.

NO ADVARSEL:

SIKKERHETEN TIL DETTE APPARATET GARANTERES KUN HVIS DU OVERHOLDER DISSE INSTRUKSJONENE; HUSK Å OPPBEVARE DEM PÅ ET TRYGT STED.

SV OBSERVERA!

UTRUSTNINGENS SÄKERHET KAN ENDAST GARANTERAS OM DESSA ANVISNINGAR RESPEKTERAS I DETALJ. SPARA DÄRFÖR DESSA ANVISNINGAR FÖR FRAMTIDA KONSULTATION.

RU ВНИМАНИЕ:

МЫ ГАРАНТИРУЕМ БЕЗОПАСНУЮ ЭКСПЛУАТАЦИЮ ИЗДЕЛИЯ ТОЛЬКО ПРИ СОБЛЮДЕНИИ СПЕДУЮЩИХ ИНСТРУКЦИЙ; С ЭТОЙ ЦЕЛЬЮ НЕОБХОДИМО СОХРАНИТЬ ДАННУЮ БРОШЮРУ.

ZH 警告

为确保该装置安全，请遵守操作指示；并于安全场所放置。

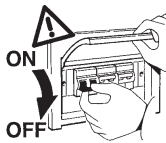

IT N.B.: DURANTE L'INSTALLAZIONE DEL SISTEMA "IN 60 LED" RISPETTARE SCRUPOLOSAMENTE LE NORME IMPIANTISTICHE NAZIONALI VIGENTI.

EN N.B.: WHEN INSTALLING THE "IN 60 LED" SYSTEM, MAKE SURE ALL CURRENT NATIONAL REGULATIONS RELATING TO INSTALLATION ARE OBSERVED.

FR N.B.: LORS DE L'INSTALLATION DU SYSTÈME "IN 60 LED" VEUILLEZ RESPECTER RIGOREUSEMENT LES NORMES EN VIGUEUR EN LA MATIÈRE DANS LE PAYS.

DE N.B.: BEACHTEN SIE BEI DER INSTALLATION DES SYSTEMS "IN 60 LED" UNBEDINGT DIE IM LAND GELTENDEN ANLAGETECHNISCHEN VORSCHRIFTEN.

NL N.B.: BIJ HET INSTALLEREN VAN HET "IN 60 LED" SYSTEEM MOET U DE GELDENDE NATIONALE INSTALLATIENORMEN STRIKT NALEVEN.

ES NOTA: DURANTE LA INSTALACIÓN DEL SISTEMA "IN 60 LED" RESPETAR ESCRUPULOSAMENTE LAS NORMAS NACIONALES DE INSTALACIÓN EN VIGOR.

DA N.B.: UNDER INSTALLATION AF "IN 60 LED" SYSTEMET SKAL MAN NØJE OVERHOLDE DE GÆLDENDE REGLER FOR DISSE ANLÆG.

NO N.B.: UNDER INSTALLASJON AV SYSTEMET "IN 60 LED" MÅ DE NASJONALE ANLEGGSFORSKRIFTENE OVERHOLDES NØYE.

SV OBS! UNDER INSTALLATIONEN AV SYSTEMET "IN 60 LED" SKA GÄLLANDE NATIONELLA INSTALLATIONSFÖRESKRIFTER RESPEKTERAS I DETALJ.

PRIMECHANIJE: В ПРОЦЕССЕ МОНТАЖА СИСТЕМЫ "IN 60 LED" СТРОГО СОБЛЮДАЙТЕ НАЦИОНАЛЬНЫЕ ДЕЙСТВУЮЩИЕ НОРМАТИВЫ ПО ЭЛЕКТРОПРОВОДКЕ.

ZH 重要：安装 "IN 60 LED" 系统时请始终参照标准系统

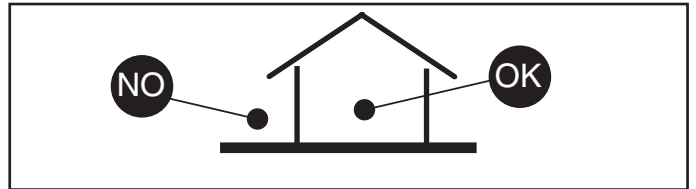

IT INSTALLAZIONE SUL CONTROSOFFITTO

EN INSTALLATION ON CEILING

FR INSTALLATION AU FAUX-PLAFOND

DE INSTALLATION AN DER HÄNGEDECHE

NL HET INSTALLEREN IN HET VERLAAGDE PLAFOND

ES INSTALACION SOBRE FALSO TECHO

DA INSTALLATION PÅ FORSÆNKET LOFT

NO MONTERING I TAKET

SV INSTALLATION I UNDERTAK

RU МОНТАЖ В ФАЛЬШ-ПОТОЛКЕ

ZH 吸顶式安装天花板上的安装

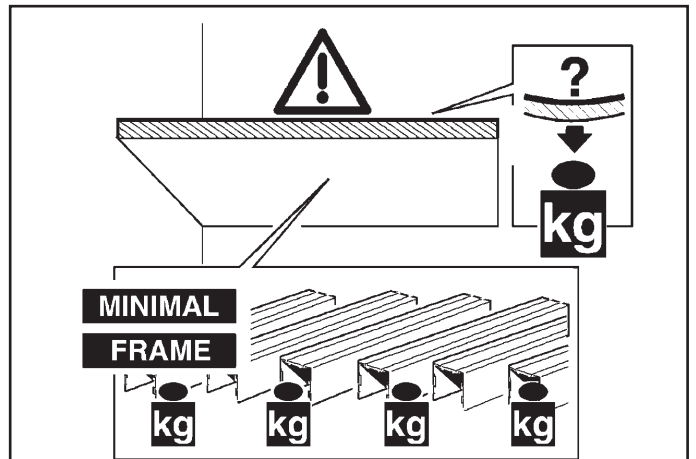

IT N.B.: E' responsabilita' dell'utente verificare la resistenza del controsoffitto, in funzione del peso degli apparecchi installati.

EN N.B.: It is the user's responsibility to check the strength of the false ceiling with respect to the weight of the fixtures installed.

FR N.B.: Il appartient à l'utilisateur de vérifier la résistance du faux plafond en fonction du poids des appareils installés.

DE N.B.: Es obliegt dem Verbraucher sicherzustellen, daß die Deckenverkleidung das Gewicht der Einbauleuchte aufnehmen kann.

NL N.B.: Het is de verantwoordelijkheid van de koper zich ervan te verzekeren dat het verlaagde plafond stevig genoeg is voor het dragen van het gewicht van de geïnstalleerde apparaten.

ES NOTA: Corresponde al usuario efectuar las pruebas en el falso techo, en función del peso de los aparatos instalados.

DA N.B.: Det er brugerens ansvar, at kontrollere loftets modstandsdygtighed, ud fra de installerede apparaters vægt.

NO N.B.: Det er brukerens ansvar å kontrollere himlingens/takets motstandskraft, på grunnlag av de installerte apparatene vekt.

SV OBS! Det är användarens ansvar att kontrollera takets hållfasthet i förhållande till vikten på installerad utrustning.

RU ПРИМЕЧАНИЕ: Пользователь должен проверить прочность фальш-потолка в соответствии с весом устанавливаемых в него приборов.

ZH 注意：用户须根据安装装置的重量 检查假天花的强度。



IT N.B.: Apparecchi non idonei ad essere coperti di materiale termicamente isolante

EN N.B.: Fixtures not suitable to be covered in thermally-insulating material.

FR N.B.: Appareils ne pouvant pas être couverts de matériau d'isolation thermique

DE N.B.: Geräte nicht geeignet, um mit wärmeisolierendem Material abgedeckt zu werden

NL N.B.: Deze apparaten zijn niet geschikt om te worden bedekt met thermisch isolerend materiaal

ES NOTA: Aparatos no aptos para ser cubiertos de material térmicamente aislante

DA N.B.: Armaturerne må ikke dækkes af varmeisolerende materiale.

NO N.B.: Apparatenes passer ikke til å dekkes av termoisolerende materialer.

SV OBS! Utrustningen får inte täckas över med värmeisolerande material

RU Внимание: Приборы непригодны для покрытия термоизоляционным материалом.

ZH 灯具不适用隔热材料加以覆盖。

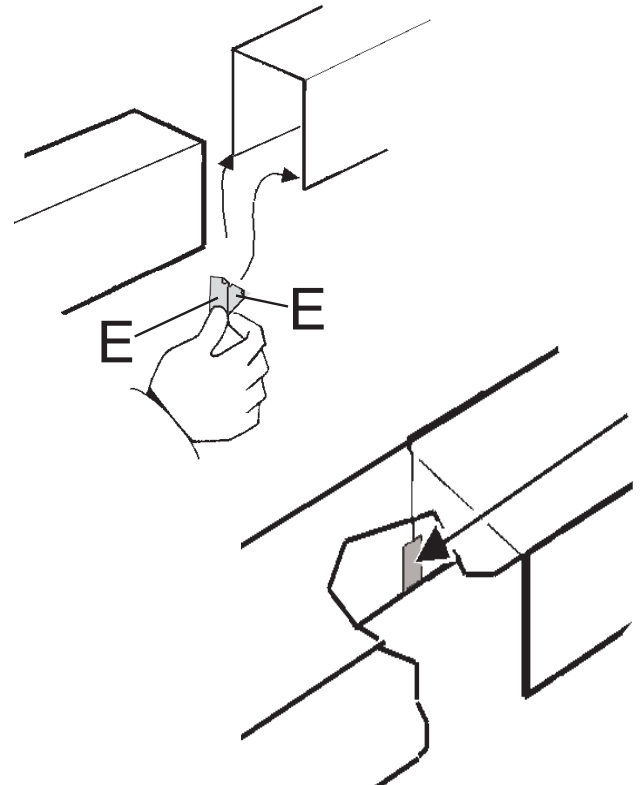
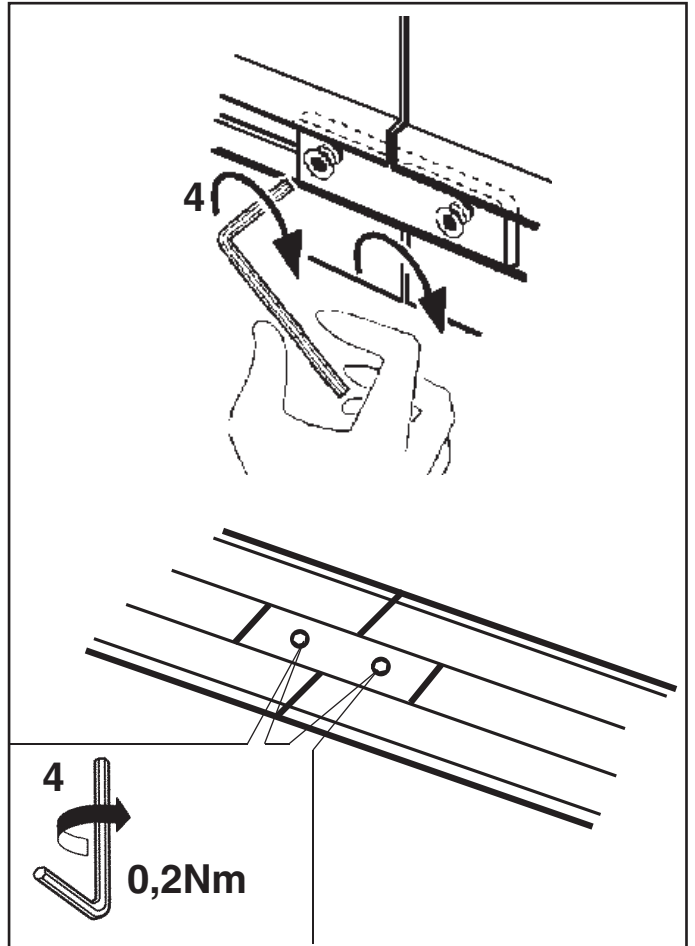
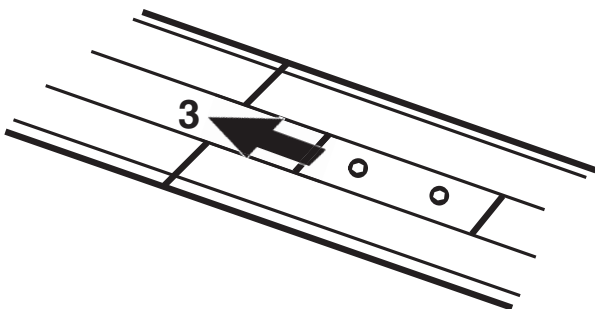
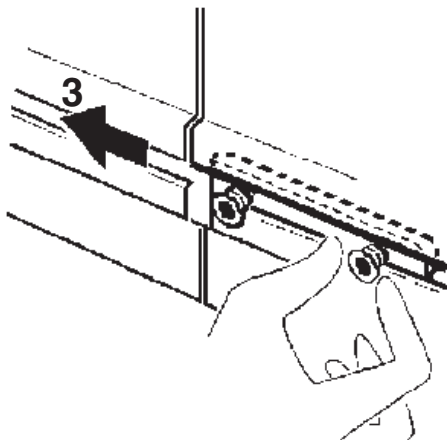
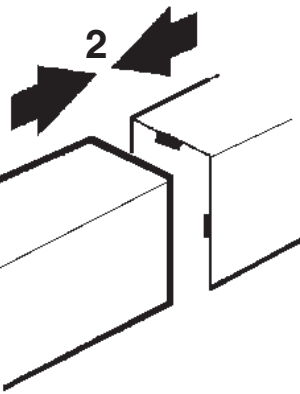
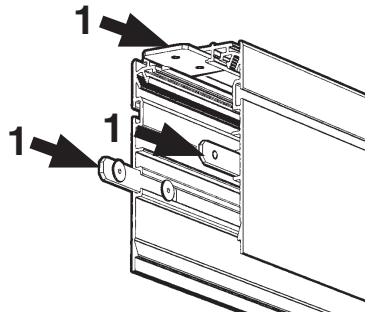
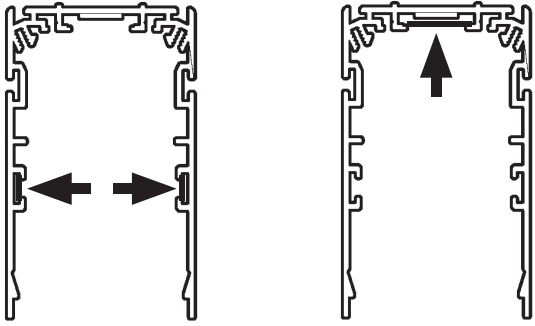

- IT Applicare l'etichetta "E" come mostrato in figura.
 EN Apply label "E" as shown in the figure.
 FR Appliquez l'étiquette "E" comme illustré (voir figure).
 DE Bringen Sie das Etikett "E" wie in der Abbildung dargestellt an.
 NL Bevestig het etiket "E" zoals aangegeven in de figuur.
 ES Aplicar la etiqueta "E" según ilustrado en la figura.
 DA Sæt mærkatet "E" på, som vist i figuren.
 NO Innrett merke "E" slik som vist på figuren.
 SV Applicera etiketten "E" enligt figuren.
 RU Нанесите этикетку «Е», как показано на схеме.
 ZH 按表中所示贴上标签"E"。

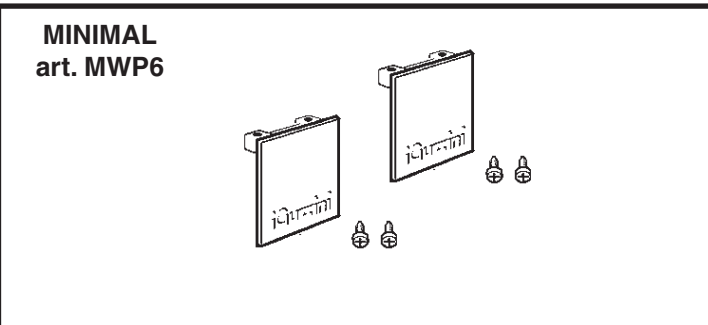
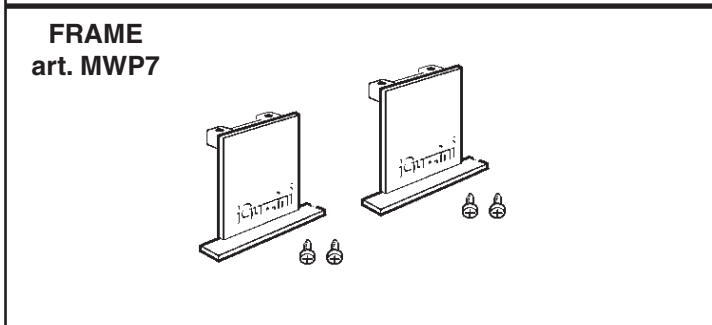
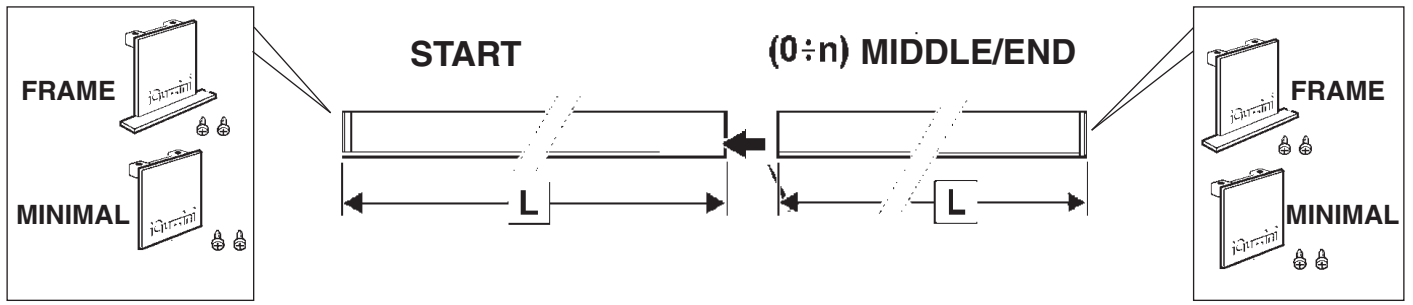

UP/ DOWN

TYPE	L (mm)	ART.	START	MIDDLE/ END	
 GENERAL LIGHTING LOW CONTRAST	1208	QA96	●		QB24 - QB26 - QB28 - QB30 - QB56 - QB58 - QB60 - QB62
	2397	QA97	●	2x	QB24 - QB26 - QB28 - QB30 - QB56 - QB58 - QB60 - QB62
	3596	QA98	●		QB25 - QB27 - QB29 - QB31 - QB57 - QB59 - QB61 - QB63
	3596	QA99		●	QB25 - QB27 - QB29 - QB31 - QB57 - QB59 - QB61 - QB63
 UGR <19°	1208	QB76	●		QC04 - QC06 - QC08 - QC10
	2397	QB77	●	2x	QC04 - QC06 - QC08 - QC10
	3596	QB78	●		QC05 - QC07 - QC09 - QC11
	3596	QB79		●	QC05 - QC07 - QC09 - QC11

DOWN

TYPE	L (mm)	ART.	START	MIDDLE/ END	
 GENERAL LIGHTING LOW CONTRAST	612	QA84 - QA90 - QZ63 - QZ57	●		QB08 - QB12 - QB16 - QB20 - QB40 - QB44 - QB48 - QB52
	898	QA88 - QA94 - QZ67 - QZ61		●	QB09 - QB13 - QB17 - QB21 - QB41 - QB45 - QB49 - QB53
	1208	QA85 - QA91 - QZ64 - QZ58	●		QB10 - QB14 - QB18 - QB22 - QB42 - QB46 - QB50 - QB54
	2397	QA86 - QA92 - QZ65 - QZ59	●	2x	QB10 - QB14 - QB18 - QB22 - QB42 - QB46 - QB50 - QB54
	3596	QA87 - QA93 - QZ66 - QZ60	●		QB11 - QB15 - QB19 - QB23 - QB43 - QB47 - QB51 - QB55
	3596	QA89 - QA95 - QZ68 - QZ62		●	QB11 - QB15 - QB19 - QB23 - QB43 - QB47 - QB51 - QB55
 UGR <19°	612	QB64 - QB70 - QZ91 - QZ85	●		QB88 - QB92 - QB96 - QC00
	898	QB68 - QB74 - QZ95 - QZ89		●	QB89 - QB93 - QB97 - QC01
	1208	QB65 - QB71 - QZ92 - QZ86	●		QB90 - QB94 - QB98 - QC02
	2397	QB66 - QB72 - QZ93 - QZ87	●	2x	QB90 - QB94 - QB98 - QC02
	3596	QB67 - QB73 - QZ94 - QZ88	●		QB91 - QB95 - QB99 - QC03
	3596	QB69 - QB75 - QZ96 - QZ90		●	QB91 - QB95 - QB99 - QC03

EXAMPLES:

ALIMENTAZIONE
POWER SUPPLY
ALIMENTATION
EINSPEISUNG
STROOMVERZORGING
ALIMENTACION
STRØMFORSYNING
STRØMFORSYNING
ELFØRSØRJNING
ЭЛЕКТРОПИТАНИЕ
电源

ALIMENTAZIONE
POWER SUPPLY
ALIMENTATION
EINSPEISUNG
STROOMVERZORGING
ALIMENTACION
STRØMFORSYNING
STRØMFORSYNING
ELFØRSØRJNING
ЭЛЕКТРОПИТАНИЕ
电源

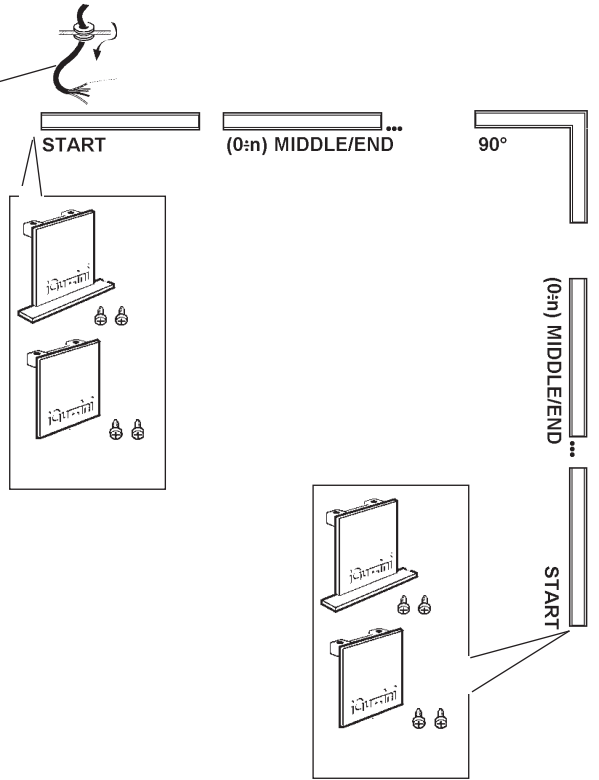
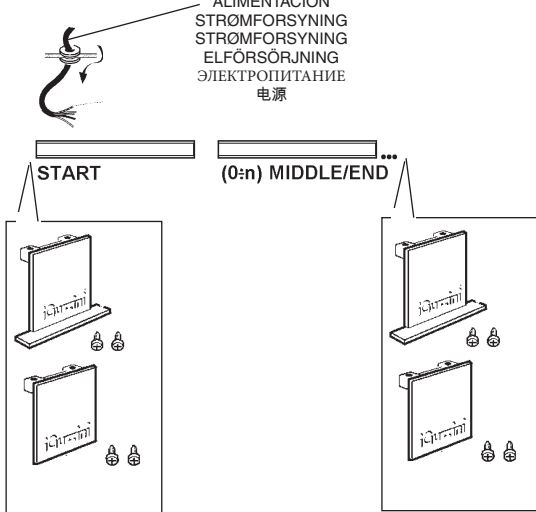

ALIMENTAZIONE
POWER SUPPLY
ALIMENTATION
EINSPEISUNG
STROOMVERZORGING
ALIMENTACION
STRØMFORSYNING
STRØMFORSYNING
ELFØRSØRJNING
ЭЛЕКТРОПИТАНИЕ
电源

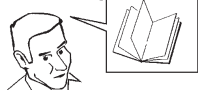
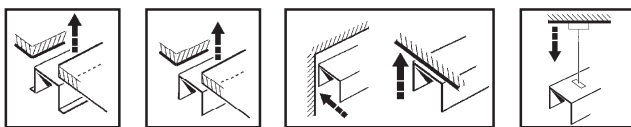
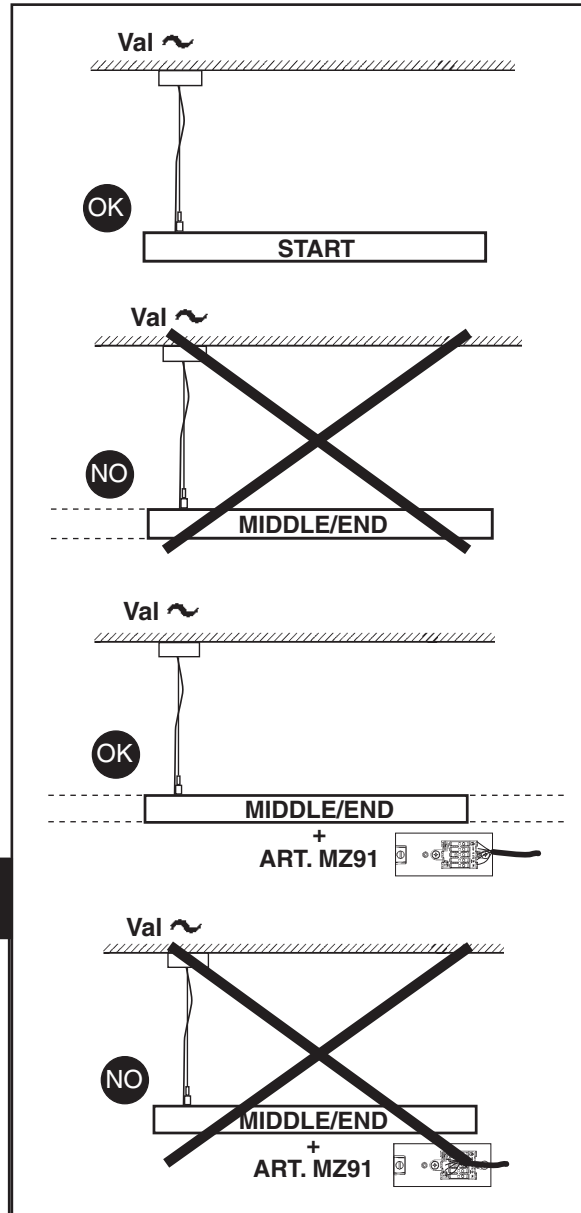
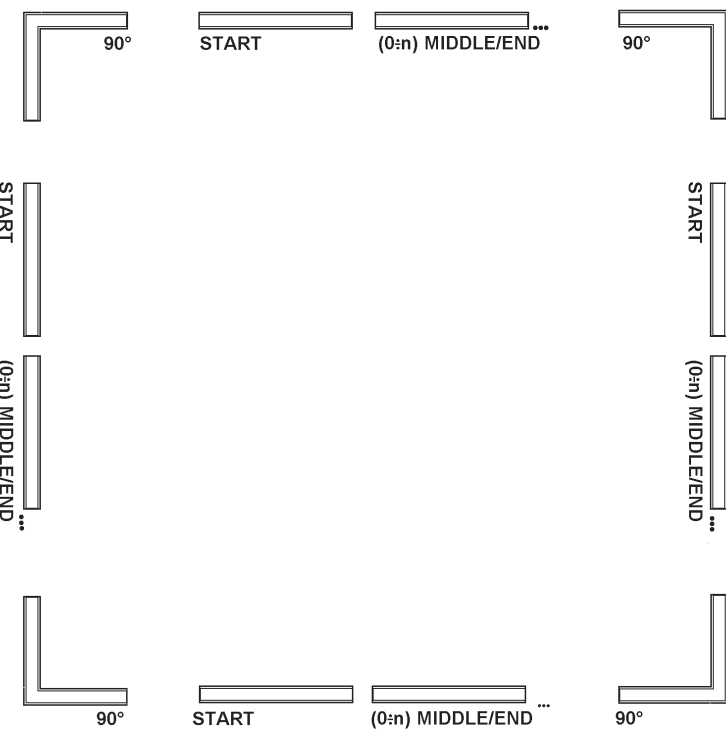

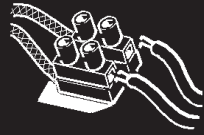

IT DETERMINAZIONE DELLE CORRENTI MASSIME AMMISSIBILI
 EN DETERMINING THE MAXIMUM PERMITTED CURRENT
 FR DETERMINATION DES COURANTS MAXIMAUX ADMISSIBLES
 DE BESTIMMUNG DER ZULÄSSIGEN HÖCHSTSTRÖME
 NL VASTSTELLEN VAN DE MAXIMAAL TOEGESTANE STROOMTOEVOER
 ES DETERMINACIÓN DE LAS CORRIENTES MÁXIMAS PERMITIDAS
 DA BESTEMMELSE AF MAKS. TILLADT STRØMSTYRKE
 NO BESTEMME MAKSIMAL TILLATT STRØM
 SV FASTSTÄLLANDE MAX. TILLÅTEN STRÖM
 RU ОПРЕДЕЛЕНИЕ МАКСИМАЛЬНОГО ДОПУСТИМОГО ТОКА
 ZH 确定最大通过电流

IT Nella progettazione dell'impianto illuminotecnico ed elettrico, determinare le correnti massime ammissibili, considerando i seguenti fattori:
 - 9A corrente nominale ammessa dai morsetti
 - coefficiente di sicurezza per tenere conto delle sovratensioni e contemporaneità;
 - corrente nominale assorbita dai singoli moduli (vedi tabella)

EN When planning the lighting and electrical system, determine the maximum permitted current taking into account the following factors:
 - 9A the nominal current permitted by terminal block
 - safety coefficient to allow for excess voltage and contemporaneity
 - the nominal current absorbed by single modules (see table)

FR Lors de l'étude de projet de l'installation d'éclairage et de l'installation électrique, déterminer les courants maximaux admissibles en tenant compte des facteurs suivants :
 - 9A courant maximal admis par le bornier
 - coefficient de sécurité tenant compte des surtensions et de la simultanéité;
 - courant nominal absorbé par les différents modules (voir tableau)

DE Bei der Planung einer Beleuchtungs- und Elektroanlage bestimmen Sie die zulässigen Höchstströme unter Berücksichtigung folgender Faktoren:
 - 9A von den Klemmleiste zugelassener Nennstrom
 - Sicherheitskoeffizient zur Einbeziehung von Überspannung und Gleichzeitigkeit;
 - von den einzelnen Modulen aufgenommener Nennstrom (siehe Tabelle)

NL Bij het ontwerpen van de verlichtingstechnische en elektrische installatie moet u de maximaal toegestane stroomtoevoer vaststellen door rekening te houden met de volgende factoren:
 - 9A nominale stroom toegestaan op klemmenstroken
 - veiligheidscoëfficiënt om rekening te houden met overspanning en gelijktijdigheid;
 - nominale opgenomen stroom van de enkele modules (zie tabel)

ES Durante la proyectación de la instalación luminotécnica y eléctrica, determinar las corrientes máximas permitidas, en consideración de los factores siguientes:
 - 9A corriente nominal permitida de la bornera
 - coeficiente de seguridad para considerar sobretensiones y contemporaneidades
 - corriente nominal absorbida por los módulos individuales (ver tabla)

DA I projekteringen af det belysningstekniske og elektriske anlæg, skal man undersøge der maks. tilladte strømstyrke, idet man tager højde for følgende:
 - 9A den nominelle, tilladte strømstyrke fra klæmkerne
 - sikkerhedsfaktor for at sikre mod overspænding og samtidighedsfaktor
 - absorberet nominel strømstyrke på de enkelte moduler (se tabellen).

NO Ved planlegging av lys- og elektrisk system, bestem maksimalt tillatt strøm, ta med i betraktningen følgende faktorer:
 - 9A nominell strøm tillatt av terminalblokkene
 - sikkerhetskoeffisiens for å tillate overflødig spenning og aktualitet,
 - nominell strøm absorbert av enkeltmoduler (se tabell)

SV Vid projekteringen av belysningssystemet och det elektriska systemet ska max. tillåten ström fastställas. Ta hänsyn till följande faktorer:
 - 9A Tillåten nominell ström från kopplingsplintarna
 - Säkerhetskoefficient för att ta hänsyn till överspänningar och sammanlagningar
 - Tillförd nominell ström från enskilda moduler (se tabell).

RU При расчёте светотехнической системы и электропроводки определите максимальный допустимый ток с учетом следующих факторов:
 - 9A номинальный допустимый ток на клеммных колодках
 - коэффициент безопасности для учета перенапряжения и одновременного включения различных приборов;
 - номинальный ток, поглощаемый отдельными модулями (см. таблицу)

ZH 规划照明和电路系统时，确定最大允许电流，并考虑下列因素：
 - 9A 接线排 允许的正常电流
 - 允许超过规定电压和同时性的安全系数；
 - 为单个模块使用的常规电流（见表）

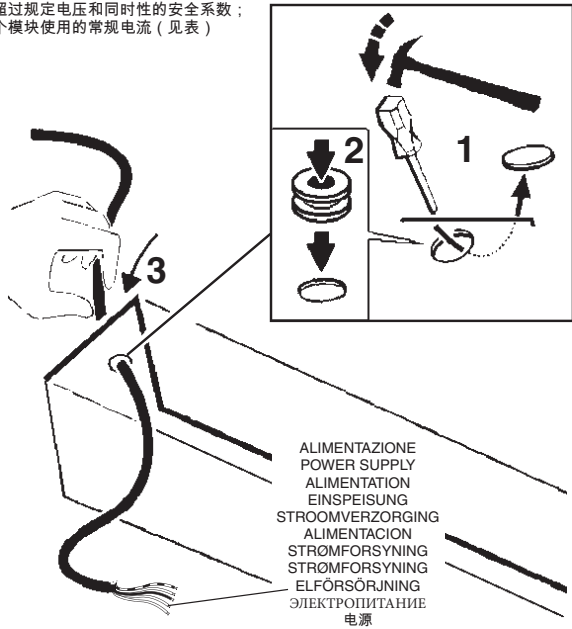

IT Utilizzare l'art. MZ91 ogni qual volta è necessario effettuare una nuova calata di alimentazione. (vedere tabella delle correnti massime ammissibili.)
 EN Use item MZ91 whenever it is necessary to effect a new power extension. (see maximum tolerable currents table)
 FR Utiliser l'art. MZ91 chaque fois qu'il faut réaliser une nouvelle arrivée d'alimentation (voir le tableau des courants maximaux admissibles).
 DE Für jede neue Aufhängung zur Stromversorgung muss der Art. MZ91 verwendet werden. (siehe Tabelle der zulässigen Höchstströme.)
 NL Gebruik het art. MZ91 elke keer dat het noodzakelijk is een nieuwe directe bekabeling uit te voeren vanaf het lichtnet. (zie tabel van de maximaal toegestane stroom.)
 ES Utilizar el art. MZ91 cada vez que se necesita efectuar una nueva alimentación intermedia. (véase tabla de las corrientes máximas permitidas)
 DA Anvend art. MZ91, når det er nødvendigt at udføre et nyt forsyningsfald (se tabel over maksimalt tilladte strøm).
 NO Bruk art.MZ91 hver gang du trenger å redusere strømtilførselen igjen (se tabellen for maks. tillatt strømstyrke).
 SV Använd art. MZ91 varje gång som det är nödvändigt att utföra en ny nätanslutning. (se tabellen för tillåten maximiström.)
 RU Использовать арт.МЗ91 для каждого независимого подвода питания (см. таблицу максимально допустимого тока).
 ZH 每次执行新的电源下降时使用零件MZ91 (参见最大允许电流表格)。

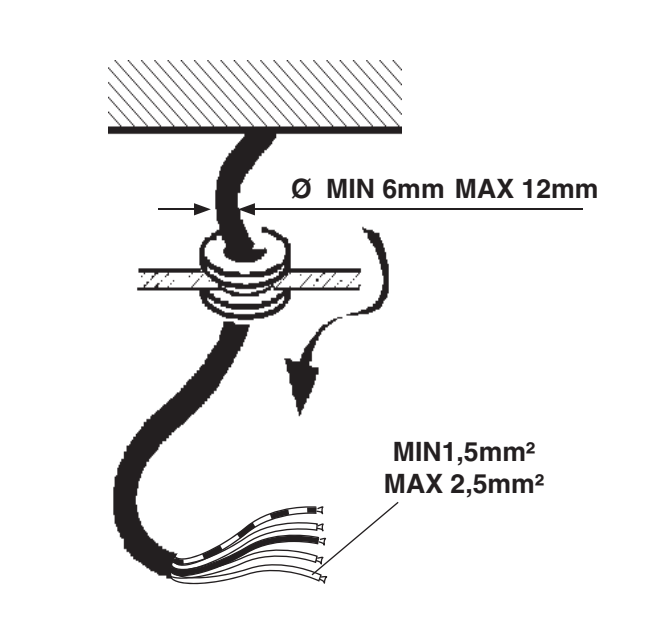
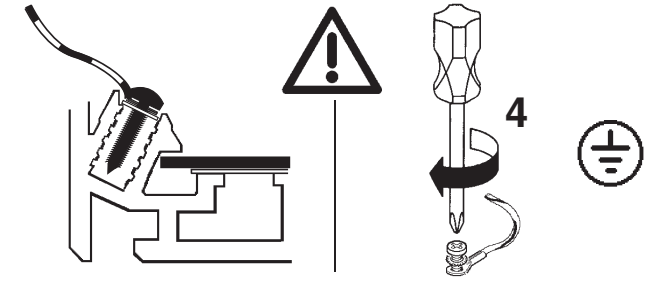
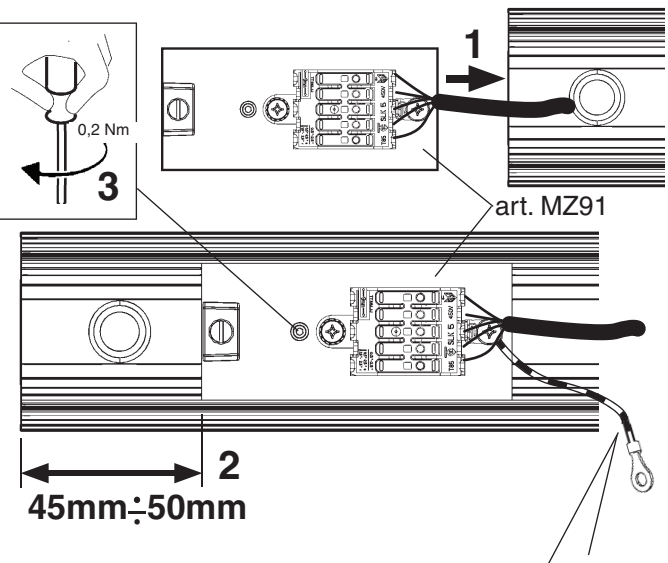

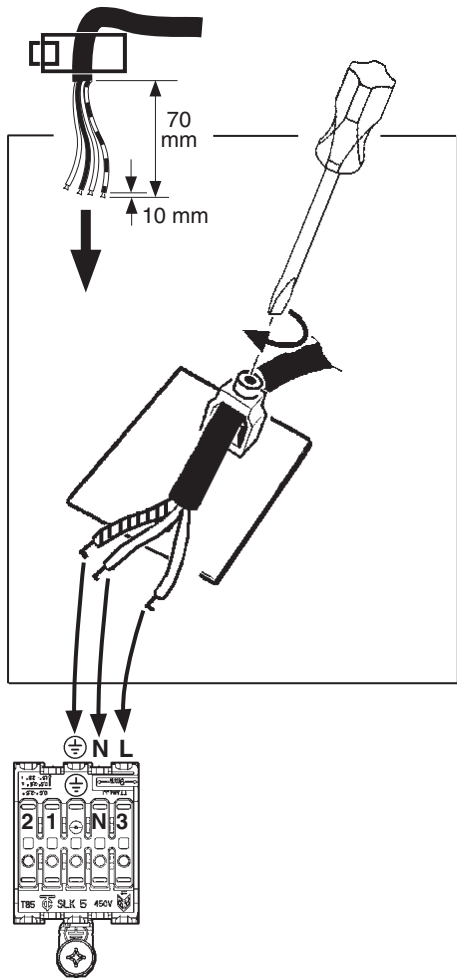

DALI

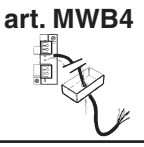
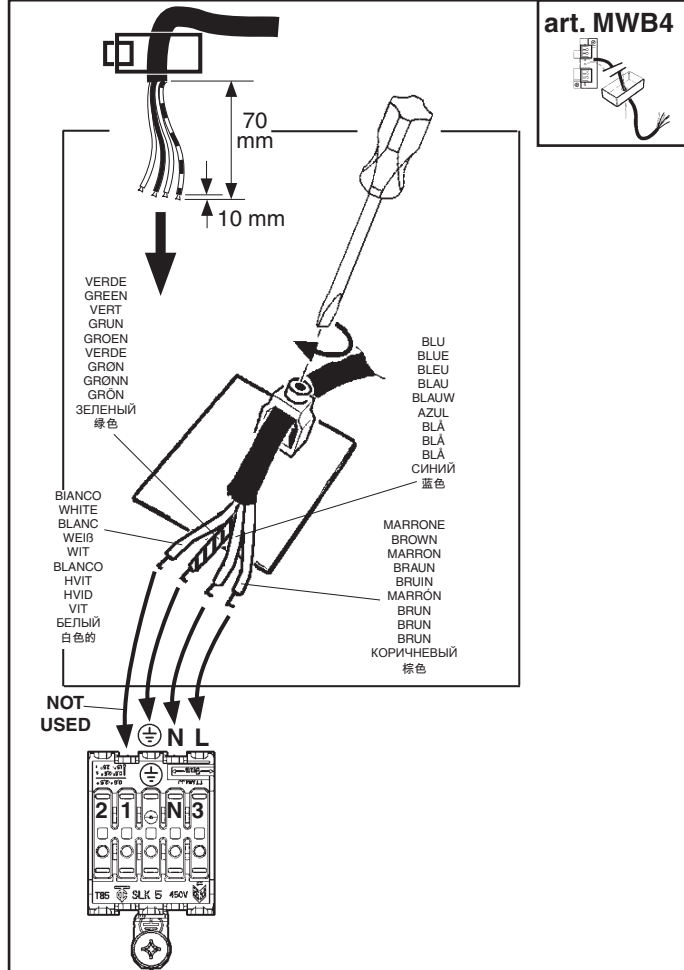
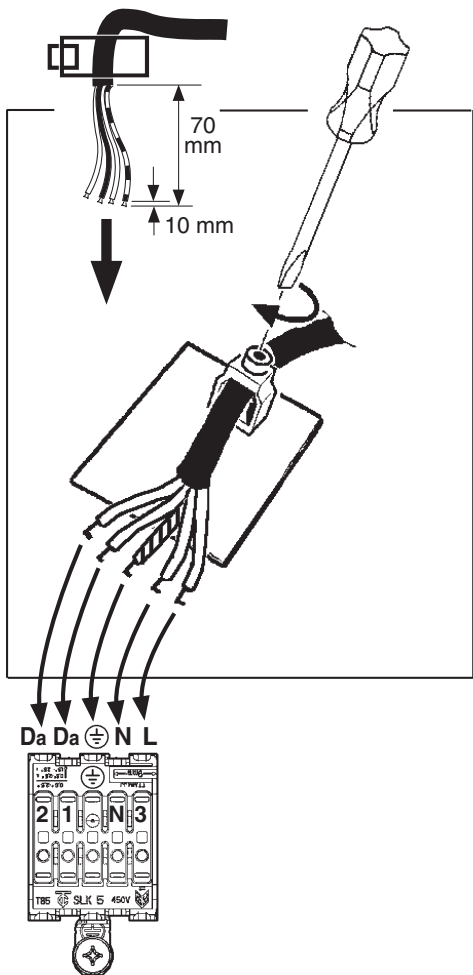

DALI

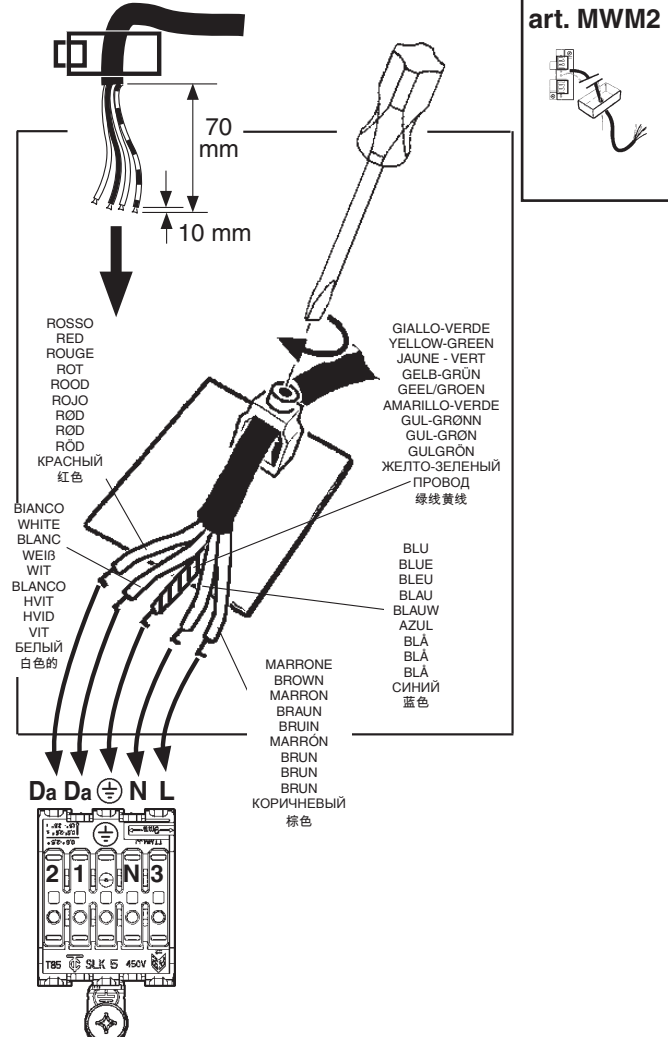

TOUCH DIM

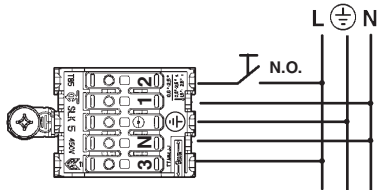

- IT** I dispositivi con cablaggio digitale possono essere dimmerati con dispositivi DALI o con pulsante normalmente aperto (N.O.) da collegare come da schema.
- EN** Devices with digital control gear may be dimmed using DALI devices or a normally-open button (N.O.) to be connected as shown in the diagram.
- FR** Les articles à câblage numérique peuvent fonctionner avec des variateurs à dispositifs DALI ou à bouton poussoir normalement ouvert (N.O.) à relier conformément au schéma.
- DE** Die Geräte mit digitaler Verkabelung können mit Hilfe von DALI-Vorrichtungen oder mit Hilfe eines gemäß Schaltplan anzuschließenden Schließers (N.O.) gedimmt werden.
- NL** De producten met digitale bekabeling kunnen worden gedimd met DALI systemen of met een N.O. (normally open) knop, die moet worden aangesloten volgens schema.
- ES** Los dispositivos con cableado digital pueden regularse con dispositivos DALI o con un interruptor de botón normalmente abierto (N.O.) que se conecta según ilustrado en el esquema.
- DA** Produkter med digital kabelføring kan dæmpes med DALI-anordninger eller med kontakten, som normalt er åben (N.O.) og som skal tilsluttes, som vist.
- NO** Produkter med digitalkabler kan dimmes med DALI-anordninger eller med en normalt åpen (NO) trykkbryter som kobles som vist i koblingsskjema.
- SV** Produkter med digital kabeldragning kan föräses med dimmer. Detta kan göras med DALI-anordningarna eller med en normalt öppen kontakt (N.O.) som ska anslutas enligt schemat.
- RU** Интенсивность приборов с цифровой проводкой может регулироваться посредством устройств DALI или нормально разомкнутой кнопкой (Н.Р.), подсоединяемой согласно схеме.
- ZH** 带有数字控制装置的设备可以通过 DALI (数字化可寻址调光接口) 设备或者一个连接方式如图中所示的常开按钮 (N.O.) 进行亮度调节

- IT** Pilotare diversi prodotti DALI tramite pulsante (es: Touch-dim, Switch-dim, Push-dim, Direct-dim, etc.) potrebbe causare dei problemi di sincronizzazione tra gli stessi. È possibile ovviare a questo problema dotandosi di dispositivi aggiuntivi. Per maggiori informazioni vi invitiamo a contattarci direttamente.
- EN** Controlling different DALI products through buttons (e.g.: Touch-dim, Switch-dim, Push-dim, Direct-dim, etc.) may lead to product synchronisation problems. This problem can be overcome by using additional devices. For further information, please contact us directly.
- FR** Piloter plusieurs produits DALI par bouton (ex : Touch-dim, Switch-dim, Push-dim, Direct-dim, etc.) pourrait causer des problèmes de synchronisation entre eux. Ce problème peut être évité en s'équipant de dispositifs supplémentaires. Pour de plus amples renseignements, veuillez nous contacter directement.
- DE** Die Steuerung verschiedener DALI-Produkte mittels Taste (z.B.: Touch-dim, Switch-dim, Push-dim, Direct-dim etc.) kann eventuell zu Synchronisierungsproblemen zwischen diesen führen. Dieses Problem lässt sich durch den Einsatz von zusätzlichen Geräten beheben. Wenn Sie weitere Informationen wünschen, setzen Sie sich bitte direkt mit uns in Verbindung.
- NL** Het besturen van verschillende DALI producten m.b.v. dezelfde knop (bv.: Touch-dim, Switch-dim, Push-dim, Direct-dim, etc.) kan synchronisatieproblemen tussen de producten opleveren. Men kan dit probleem voorkomen door extra systemen aan te sluiten. Voor verdere informatie raden we u aan direct contact met ons op te nemen.
- ES** El mando de varios productos DALI por tecla (ej: Touch-dim, Switch-dim, Push-dim, Direct-dim, etc.) podría causar problemas de sincronización entre ellos. Es posible prevenir este problema utilizando dispositivos adicionales. Para más información, contacte directamente con nosotros.
- DA** Hvis DALI-produkterne styres ved hjælp af knapperne (fx. Touch-dim, Switch-dim, Push-dim, Direct-dim osv.), kan det skabe problemer med synkronisering af samme. Dette problem kan undgås, hvis man kober ekstra enheder. For yderligere oplysninger, kontakt os direkte.
- NO** Å styre ulike DALI-produkter ved hjelp av en trykknappbryter (f.eks. touch-dim, switch-dim, push-dim, direct-dim, osv.) vil kunne føre til problemer med synkroniseringen mellom dem. Dette problemet kan løses ved hjelp av noen tilleggsinnretninger. Ta gjerne kontakt med oss for mer informasjon om dette.
- SV** Styrning av olika DALI-produkter med knapp (t.ex.: Touch-dim, Switch-dim, Push-dim, Direct-dim o.s.v.) kan orsaka synkroniseringsproblem mellan dessa. Detta problem kan åtgärdas med tillägsanordningar. För mer information kan du kontakta oss direkt.
- RU** Управление различными продуктами DALI с помощью кнопки (напр.: Touch-dim, Switch-dim, Push-dim, Direct-dim и пр.) может вызвать проблемы синхронизации между ними. Эту проблему можно устранить путем задействования дополнительных устройств. За получением более подробной информации просим Вас связаться с нами непосредственно.
- ZH** 通过按钮控制不同的 DALI 产品 (例如: 触摸调光、切换调光、按压调光、直接调光等) 可能会导致产品的同步问题。该问题可通过使用其他额外的装置加以克服。如需了解更多信息, 请直接与我们联系。

CARICO DALI / DALI LOAD CHARGE DALI (COURANT MAXI ADMISSIBLE) DALI-LAST DALI VERMOGEN CARGA DALI DALI STRØMSTYRKE BELASTNING FOR "DALI" DALI-BELASTNING МАКС. ТОК СИСТЕМЫ DALI С РЕГУЛЯЦИЕЙ ИНТЕНСИВНОСТИ СВЕТА DALI 智能调光系统允许的最大电流量	INDIRIZZI DALI DALI ADDRESSES ADRESSES DALI DALI-ADRESSEN DALI ADRESSEN DIRECCIONES DALI DALI ADRESSER ADRESSER TIL "DALI" DALI-ADRESSER ЛОГИЧЕСКИЕ АДРЕСА СИСТЕМЫ DALI DALI智能调光系统计算机指定控制参数
1 (2 mA)	1
ART. QB59 - QB63 2 (4 mA)	2

ART. QB13-QB21-QB44-QB52-QB88-QB92-QB96-QC00

- IT** NON MODIFICARE I PARAMETRI DELL'ALIMENTATORE DALI IMPOSTATI DALLA "iGuzzini".
- EN** DO NOT CHANGE THE DALI POWER-UNIT PARAMETERS SET BY "iGuzzini".
- FR** NE PAS MODIFIER LES PARAMETRES DU BALLAST DALI DÉFINIS PAR «IGUZZINI».
- DE** DIE VON „iGuzzini“ EINGESTELLTEN PARAMETER DES DALI-NETZTEILS DÜRFEN NICHT VERÄNDERT WERDEN.
- NL** NIET DE PARAMETERS VAN HET DALI-VOORSCHAKELAPPARAAT WIJZIGEN DIE DOOR "iGuzzini" ZIJN INGESTELD.
- ES** NO CAMBIAR LOS PARÁMETROS DEL ALIMENTADOR DALI PROGRAMADOS POR "iGuzzini".
- NO** FORETAGIKKE ÆNDRINGER PÅ PARAMETRENE FOR DALI STRØMFORSYNINGSENHEDEN INDSTILLET AF "iGuzzini".
- DA** PARAMETRENE SOM ER LAGT INN I DALI STRØMFORSYNINGSENHETEN FRA "iGuzzini" MÅ IKKE ENDRES.
- SV** ÄNDRA INTE PARAMETRARN FÖR REAKTORN DALI SOM HAR STÄLLTS IN AV iGuzzini.
- RU** НЕ ИЗМЕНЯТЬ ПАРАМЕТРЫ БЛОКА ПИТАНИЯ, ЗАДАННЫЕ НА ЗАВОДЕ "iGuzzini".
- ZH** 请勿改变 "iGuzzini" 设置的 DALI (数字可寻址照明接口) 电源装置参数

EXAMPLE:

START

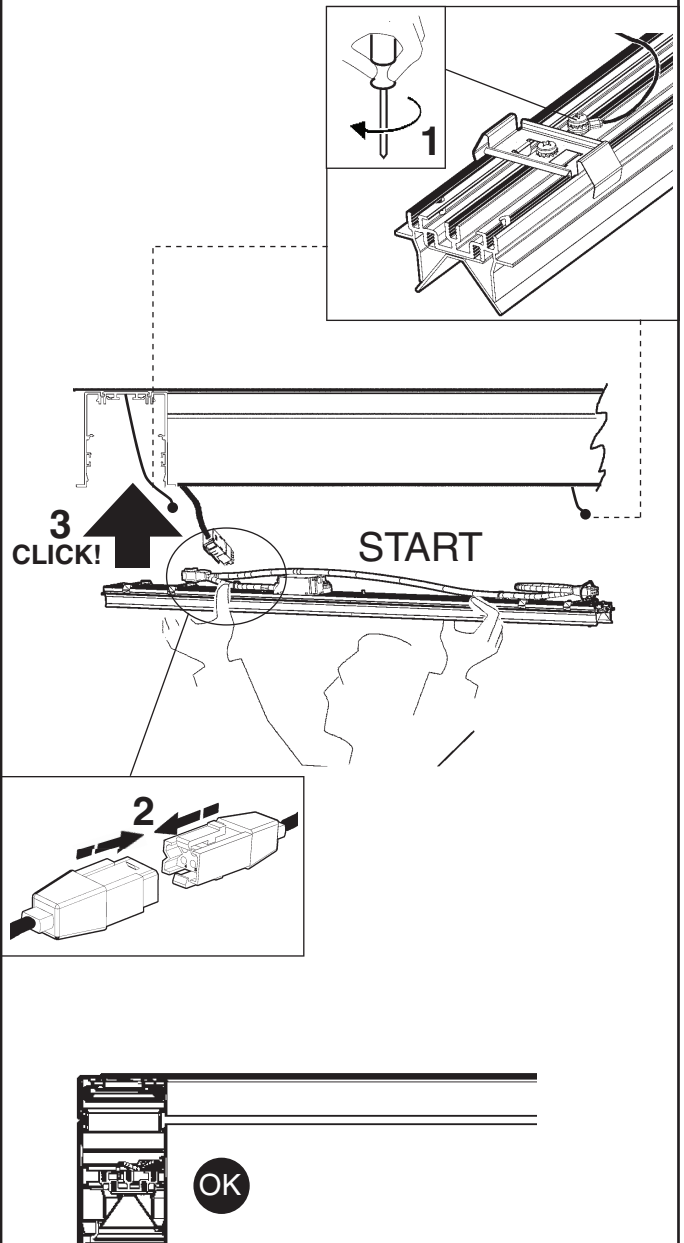

EXAMPLE:

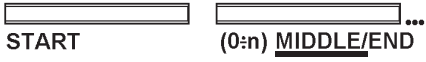

START/ MIDDLE

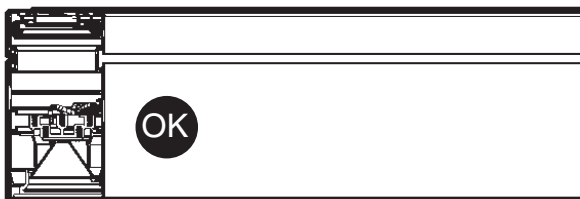
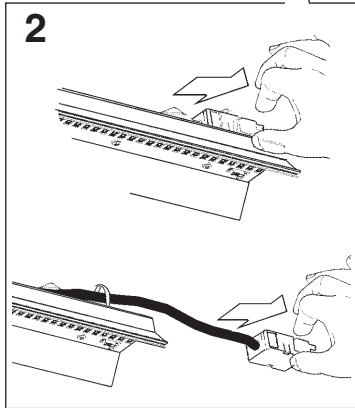
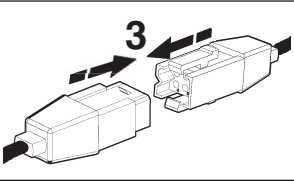
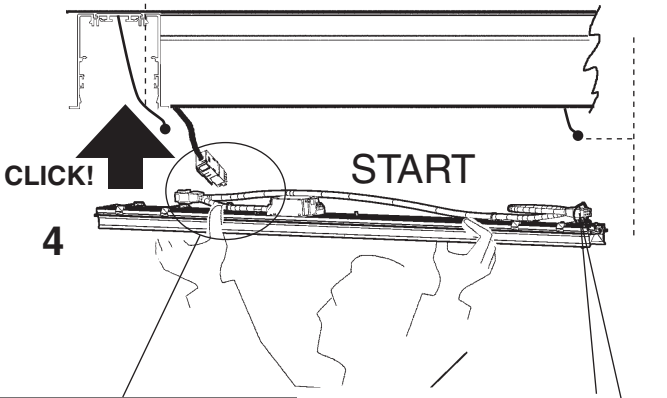
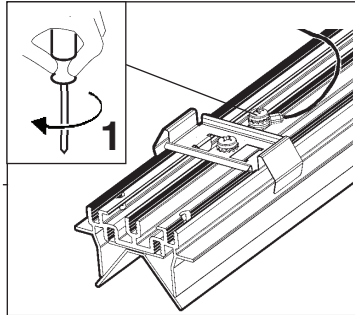

EXAMPLE:



END

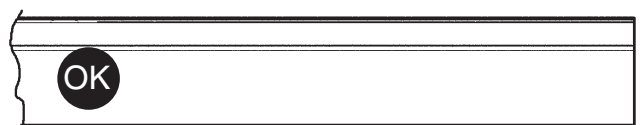
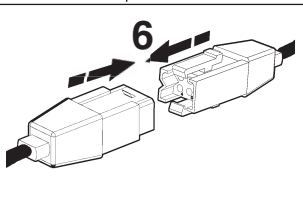
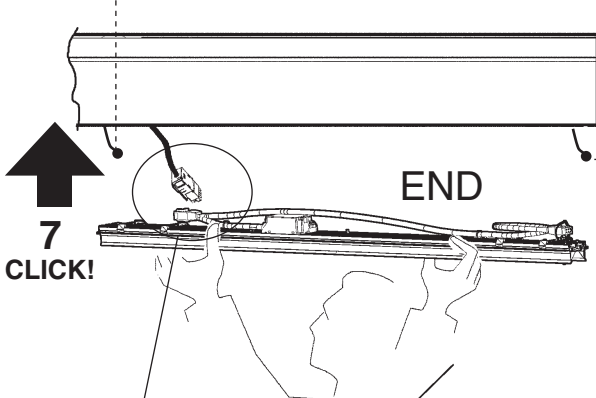
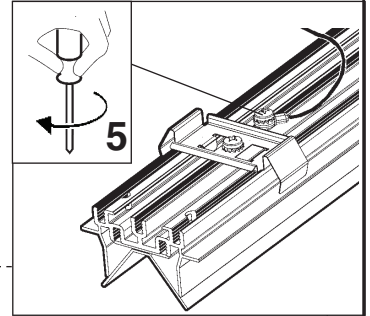

EXAMPLE:

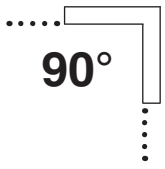

90°

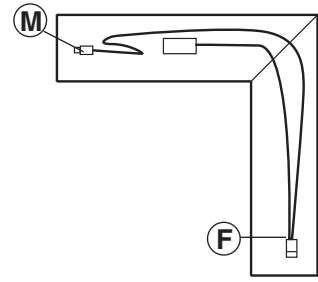
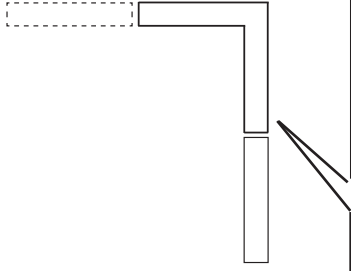

EXAMPLE:

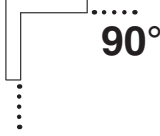

90°

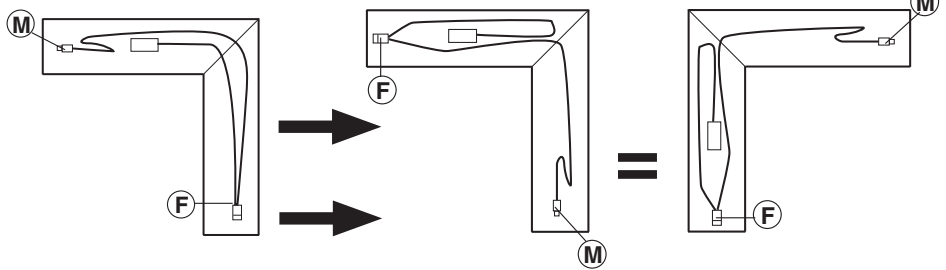

M

Maschio
Male
Male
Stecker
Mannelijk
Macho
HANSTIK
HANN-
HANE
ШТЕПСЕЛЬ
外插头

F

Femina
Female
Femelle
Buchse
Vrouwelijk
Hembra
HUNSTIK
HUNN-
HONA
ШТЕККЕР
内插头

M

1

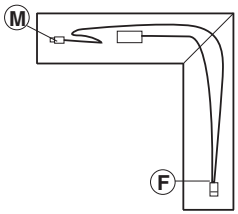

F

2



F



M

3

3

3

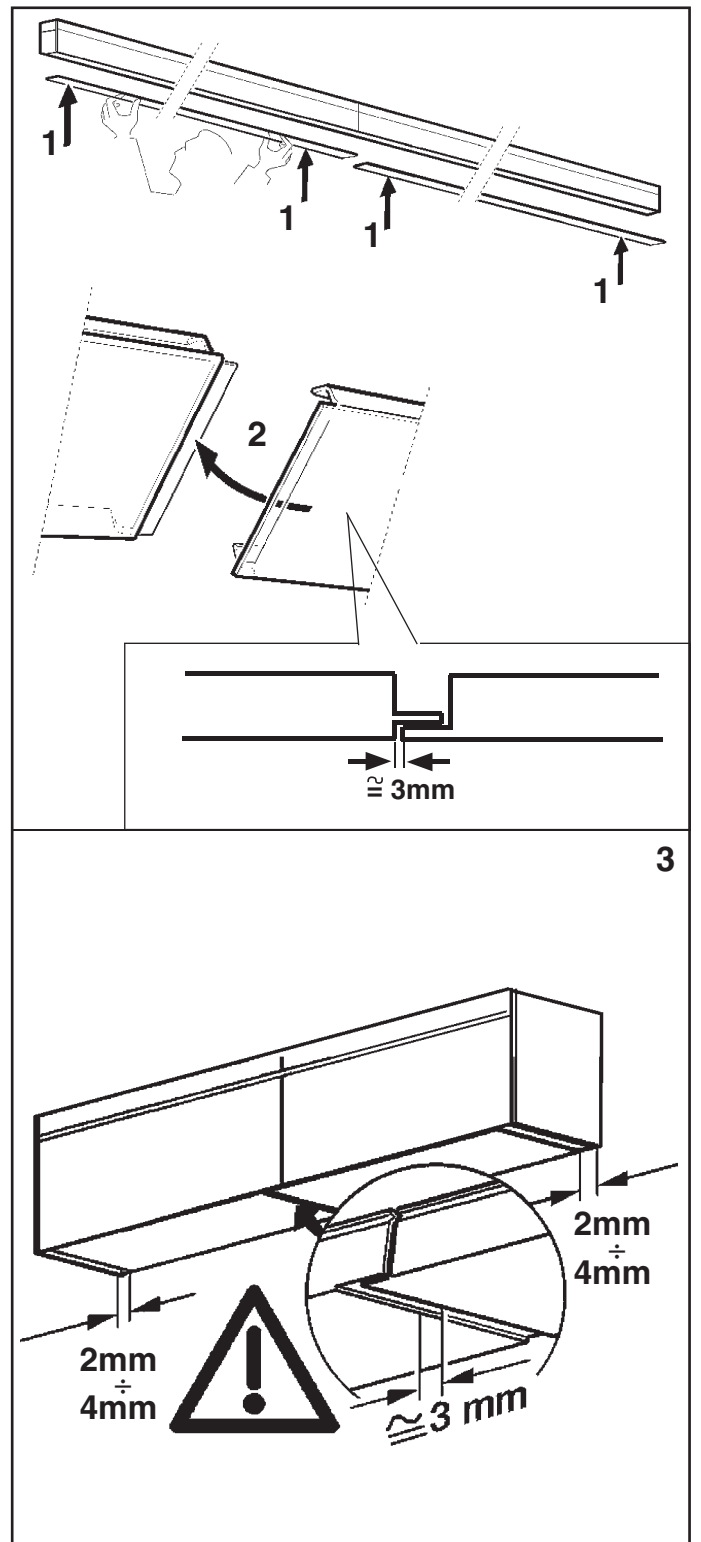
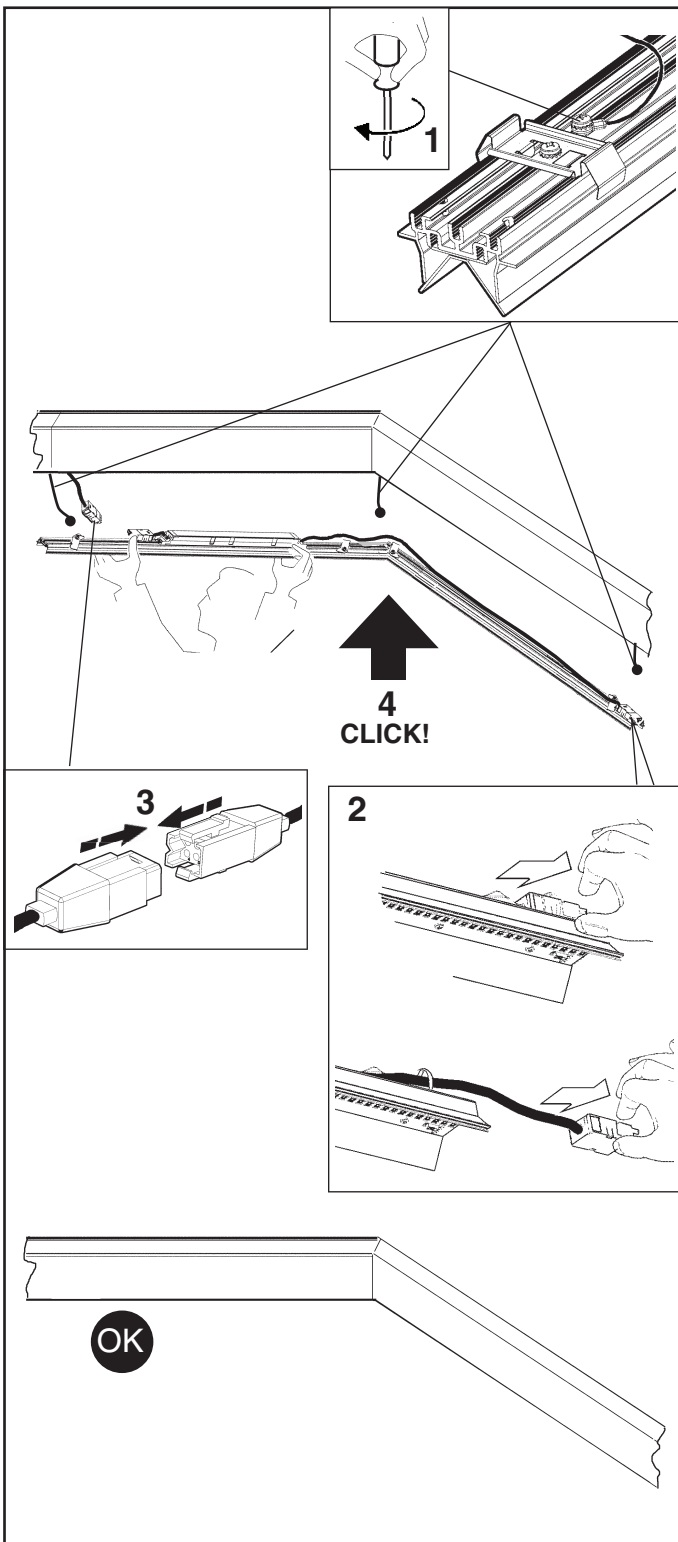
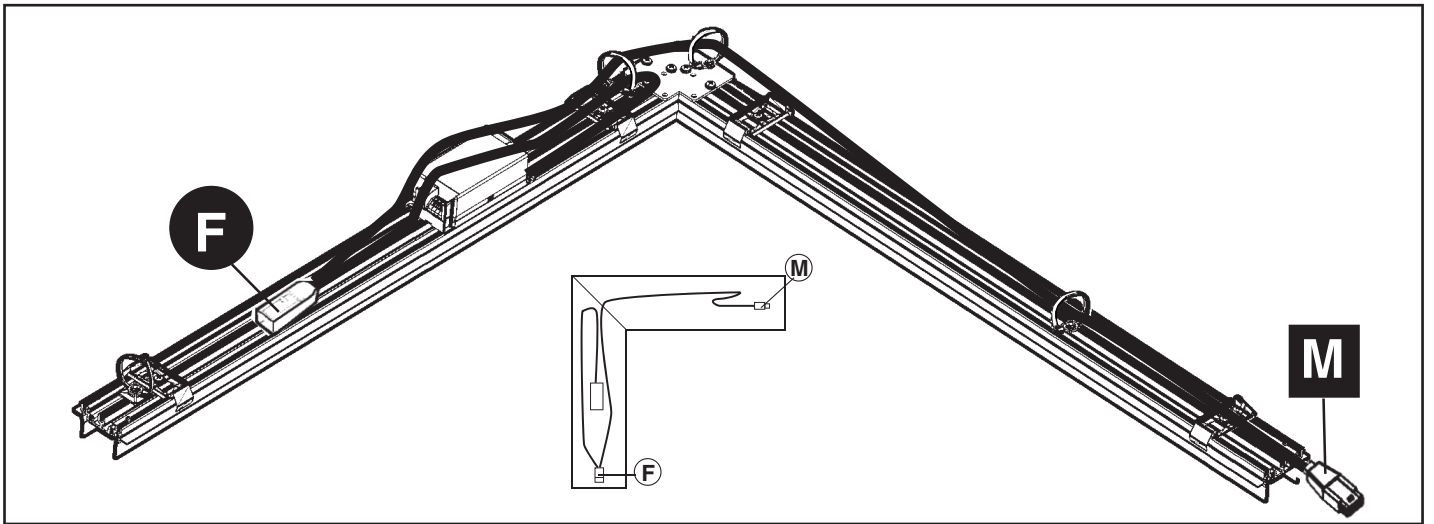

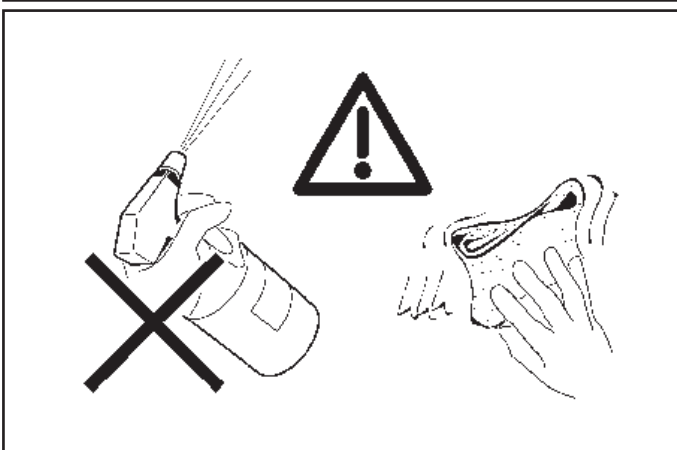
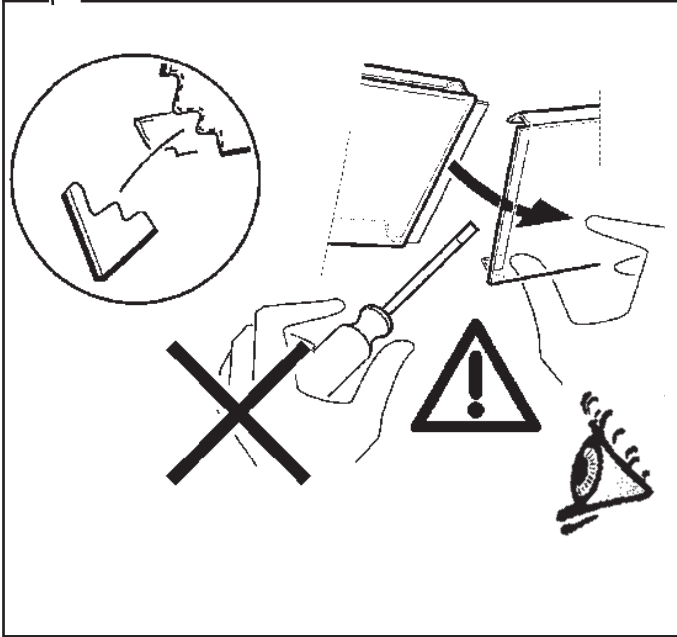
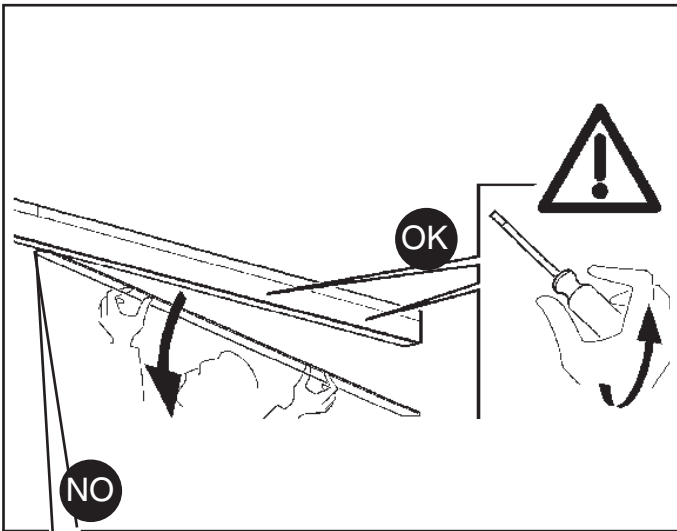

IT N.B.: Per l'eventuale pulizia non utilizzare acqua o solventi vari, usare esclusivamente panni morbidi asciutti.

EN N.B.: When cleaning, do not use water or any type of solvent. Use only soft dry cloths.

FR N.B.: En cas de nettoyage, n'utiliser ni eau ni solvants en général, n'utiliser que des chiffons doux et secs.

DE N.B.: Zur eventuellen Reinigung weder Wasser noch Lösungsmittel, sondern ausschließlich ein weiches, trockenes Tuch verwenden.

NL N.B.: Gebruik voor het sohoonmaken geen water of oplosmiddelen, maar uitsluitend zachte stofdoeken.

ES NOTA: Para la limpieza eventual no usar agua ni solventes de cualquier género, sino exclusivamente un pano suave y seco.

DA N.B.: Ved rengøring skal man undgå brug af vand eller forskellige opløsningsmidler. Brug udelukkende en tør, blød klud.

NO N.B.: For en eventuell rengjøring, ikke benytt vann eller ymse løsemidler, bruk kun tørre, myke kluter.

SV OBS! Använd inte vatten eller diverse lösningsmedel vid eventuell rengöring. Använd endast mjuka och torra trasor.

RU ПРИМЕЧАНИЕ: При необходимости произвести чистку не используйте воду или различные растворители, а исключительно сухие мягкие тряпки.

ZH 注意：不要用水或任何类型的溶剂进行清洗。只能使用干燥的软布。

IT Per le posizioni di installazione, attenersi a quelle illustrate, eventualmente contattare la iGuzzini.

EN All installation positions must comply with those illustrated. In the event of any doubt, contact iGuzzini.

FR Pour les positions d'installation, se conformer aux positions illustrées ; contacter la société iGuzzini en cas de nécessité

DE Für die Einbaupositionen die Abbildungen beachten. Eventuell iGuzzini kontaktieren.

NL Houd u voor de installatieposities aan degene die zijn weergegeven. Neem eventueel contact op met iGuzzini

ES Respetar las posiciones de instalación ilustradas y, en caso de duda, contactar con iGuzzini

DA For installationspositioner skal man holde sig til de viste, og eventuelt kontakte iGuzzini

NO For installasjonsplasseringene henviser vi til illustrasjonene, eller ta eventuelt kontakt med iGuzzini

SV Följ de angivna positionerna för installationen. Kontakta vid behov iGuzzini

RU При выборе положения для монтажа следует обратиться к проиллюстрированным либо обратиться в компанию iGuzzini

ZH 安装位置请参考图示，必要时也可联系iGuzzini

IT N.B.: Per la sostituzione del LED contattare l'azienda iGuzzini.

EN N.B.: For information on LED replacement please contact iGuzzini.

FR N.B.: Pour procéder au remplacement de la LED, adressez-vous à la société iGuzzini.

DE N.B.: Bezüglich des Austausches der LED kontaktieren Sie bitte die Firma iGuzzini.

NL N.B.: Voor het vervangen van de LED neemt u contact op met het bedrijf iGuzzini.

ES NOTA: Para sustituir el LED llame a la empresa iGuzzini.

DA N.B.: For udskiftning af lysdioden, skal man kontakte iGuzzini.

NO N.B.: For informasjon om skifte av LED, vennligst ta kontakt med iGuzzini.

SV OBS! För byte av lysdioden, kontakta företaget iGuzzini.

RU ПРИМЕЧАНИЕ: Для замены СИДов обращайтесь в компанию iGuzzini.

ZH 注意：如需LED更换的信息，请联系iGuzzini。

IN60

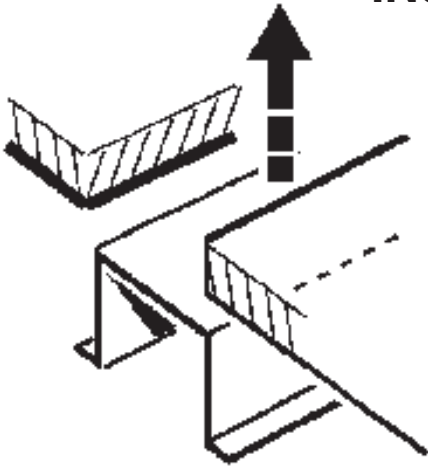

تحذير:

لا يمكن ضمان سلامة هذا الجهاز إلا إذا التزمت بهذه التعليمات. يجب حفظها في مكان آمن.

ATTENZIONE:

LA SICUREZZA DELL'APPARECCHIO E' GARANTITA SOLO CON L'USO APPROPRIATO DELLE SEGUENTI ISTRUZIONI; PERTANTO E' NECESSARIO CONSERVARLE.

WARNING:

THE SAFETY OF THIS FIXTURE IS GUARANTEED ONLY IF YOU COMPLY WITH THESE INSTRUCTIONS; REMEMBER TO CONSERVE IN A SAFE PLACE.

ATENCION:

LA SEGURIDAD DEL APARATO SE GARANTIZA SOLO CUMPLIENDO CUIDADOSAMENTE LAS SIGUIENTES INSTRUCCIONES; POR ELLO, ES NECESARIO CONSERVARLAS.

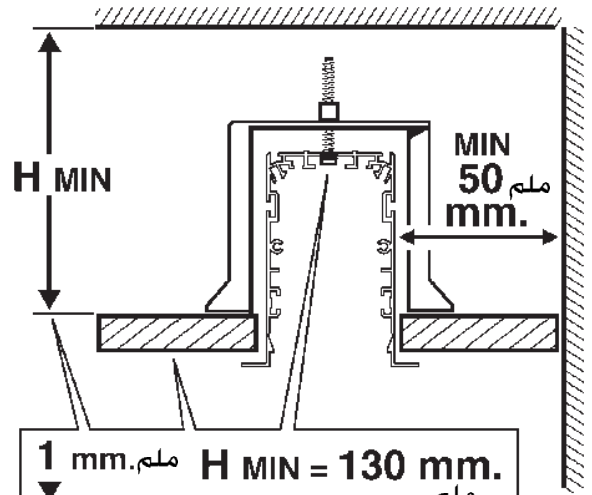

1 mm. ملم. H MIN = 130 mm.

13 mm. ملم.

M5x25

40 mm. ملم. H MIN = 150 mm.

M5x50

FRAME

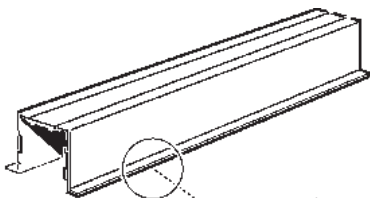

80 mm. ملم.

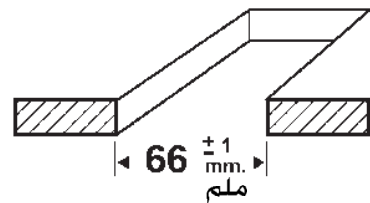
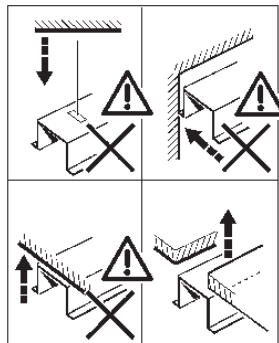

66 +1 mm. ملم.

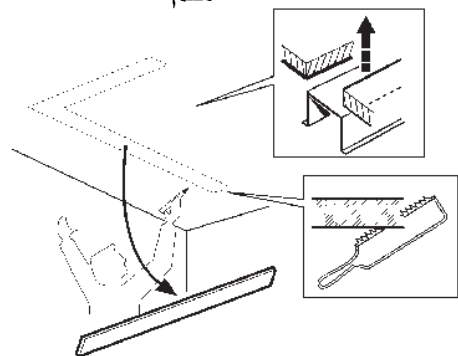

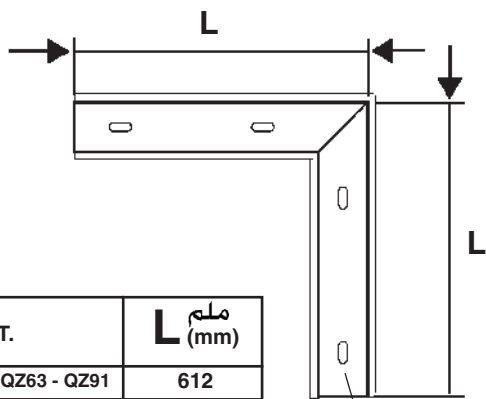
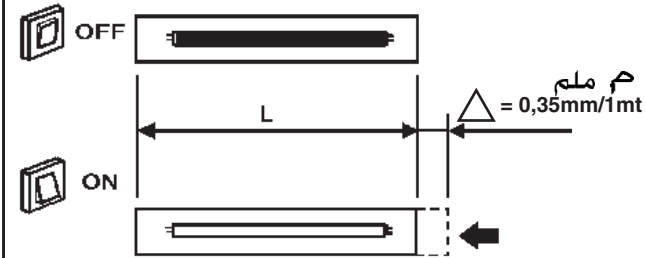
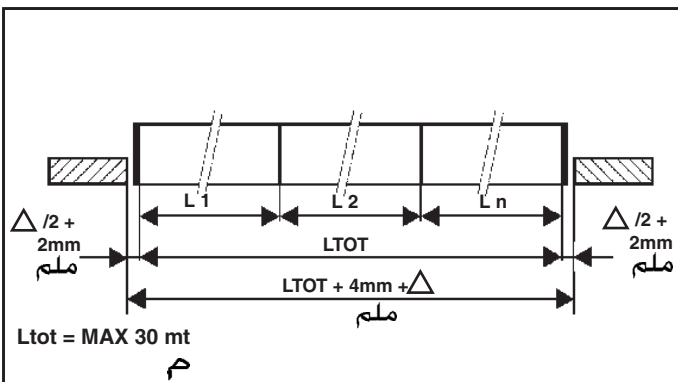

الصنف ART.	ملم (mm)
QA84 - QB64 - QZ63 - QZ91	612
QA85 - QB65 - QZ64 - QZ92	1208
QA86 - QB66 - QZ65 - QZ93	2397
QA87 - QB67 - QZ66 - QZ94	3596
QA88 - QB68 - QZ67 - QZ95	898
QA89 - QB69 - QZ68 - QZ96	3596
الصنف ART.	ملم (mm)
QB00 - QB01 - QB02 - QB03 QB32 - QB33 - QB34 - QB35 QB80 - QB81 - QB82 - QB83 QZ77 - QZ79 - QZ78 - QZ80 QZ81 - QZ83 - QZ82 - QZ84 R051 - R053 - R052 - R054	642 x 642

الصنف
 art. QB00 - QB01
 QB02 - QB03
 QB32 - QB33
 QB34 - QB35
 QB80 - QB81
 QB82 - QB83
 QZ77 - QZ79
 QZ78 - QZ80
 QZ81 - QZ83
 QZ82 - QZ84
 R051 - R053
 R052 - R054

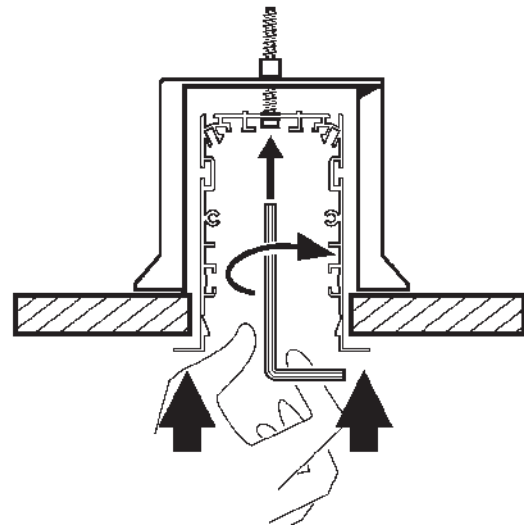
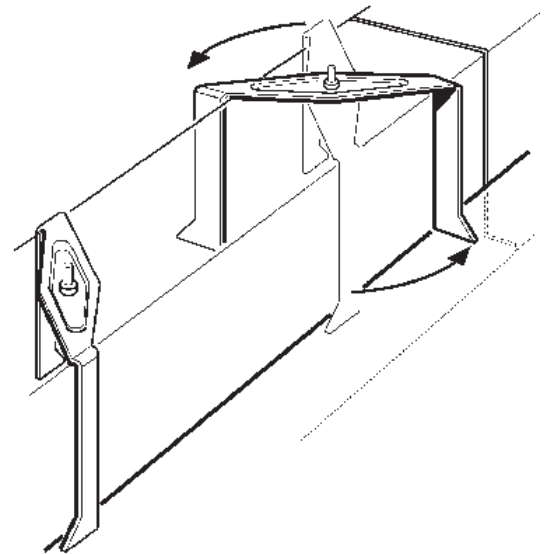
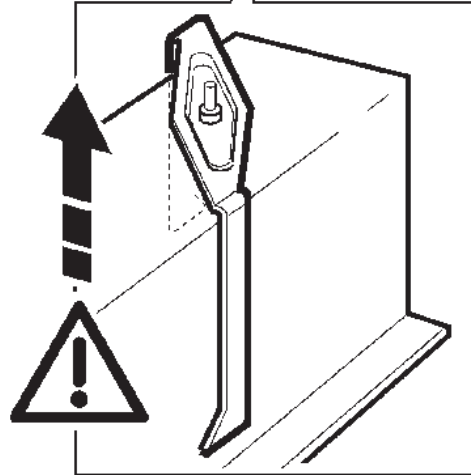
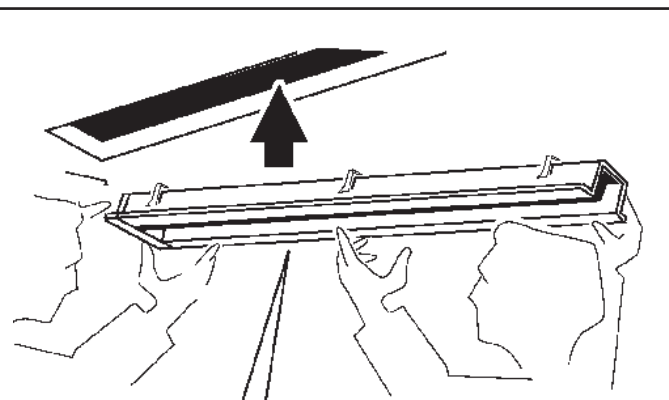

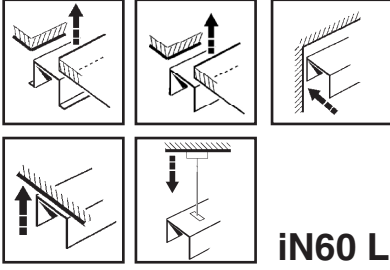

iN60 LED

تحذير:

AR لا يمكن ضمان سلامة هذا الجهاز إلا إذا التزمت بهذه التعليمات. يجب حفظها في مكان آمن.

IT **ATTENZIONE:**
LA SICUREZZA DELL'APPARECCHIO E' GARANTITA SOLO CON L'USO APPROPRIATO DELLE SEGUENTI ISTRUZIONI; PERTANTO E' NECESSARIO CONSERVARLE.

EN **WARNING:**
THE SAFETY OF THIS FIXTURE IS GUARANTEED ONLY IF YOU COMPLY WITH THESE INSTRUCTIONS; REMEMBER TO CONSERVE IN A SAFE PLACE.

ES **ATENCION:**
LA SEGURIDAD DEL APARATO SE GARANTIZA SOLO CUMPLIENDO CUIDADOSAMENTE LAS SIGUIENTES INSTRUCCIONES; POR ELLO, ES NECESARIO CONSERVARLAS.

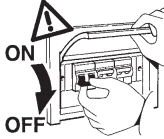

AR ملاحظة: ملاحظة: أثناء تركيب نظام "iN60" يجب التقيد بحرص بالنظم السائدة المتعلقة بالشبكة الكهربائية.

IT N.B.: DURANTE L'INSTALLAZIONE DEL SISTEMA "iN60" RISPETTARE SCRUPOLOSAMENTE LE NORME IMPIANTISTICHE VIGENTI.

EN N.B.: WHEN INSTALLING THE SYSTEM "iN60", STRICTLY COMPLY WITH ALL REGULATIONS ON INSTALLATION IN FORCE.

ES N.B.: DURANTE LA INSTALACIÓN DEL SISTEMA "iN60" RESPETAR ESCRUPULOSAMENTE LAS NORMAS DE INSTALACIÓN VIGENTES.



التركيب على السقف

INSTALLAZIONE SUL CONTROSOFFITTO
INSTALLATION ON CEILING
INSTALACION SOBRE FALSO TECHO

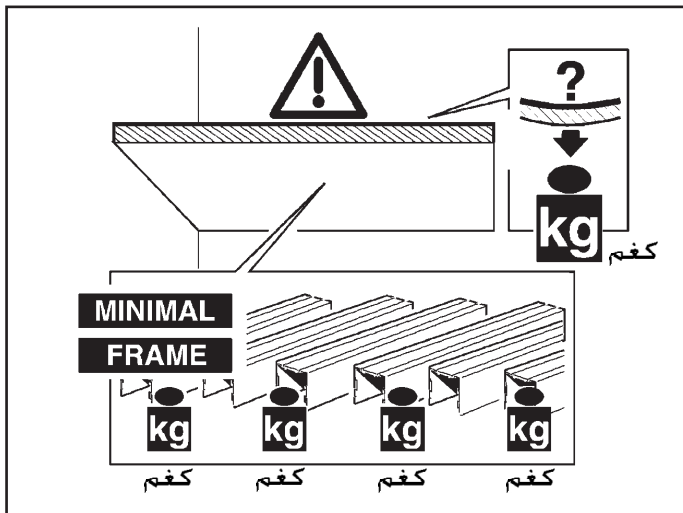

AR ملاحظة: يتحمل المستخدم مسؤولية التحقق من صلابة السقف ونظام التعليق بناء على وزن الأجهزة المركبة.

IT N.B.: E' responsabilità dell'utente verificare la resistenza del soffitto e del sistema di fissaggio, in funzione del peso degli apparecchi installati.

EN N.B.: It is the user's responsibility to check the resistance of the ceiling and the anchoring system, in accordance with the weight of the luminaries.

ES Nota: Es responsabilidad del usuario verificar la resistencia del techo y del sistema de fijación, según el peso de los aparatos instalados.

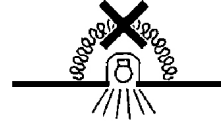

AR ملاحظة: أجهزة غير قابلة للتغطية مواد عازلة حرارياً.

IT N.B.: Apparecchi non idonei ad essere coperti di materiale termicamente isolante

EN N.B.: Fixtures not suitable to be covered in thermally-insulating material.

ES OBS! Utrustningen får inte täckas över med värmeisolerande material

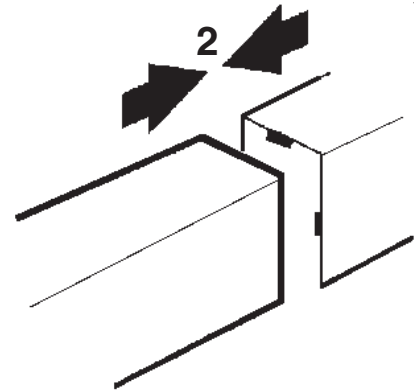
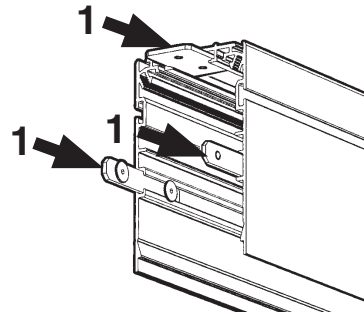
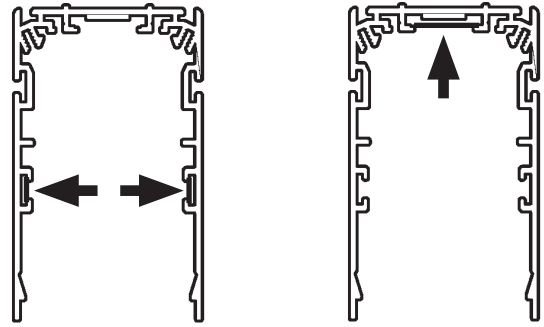

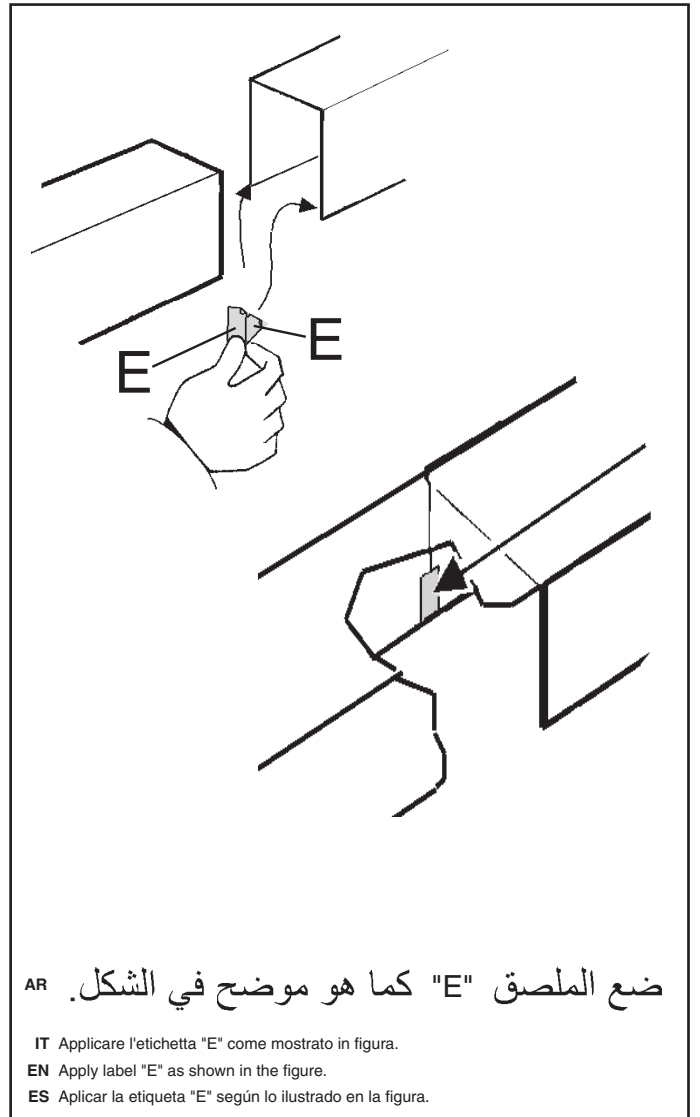
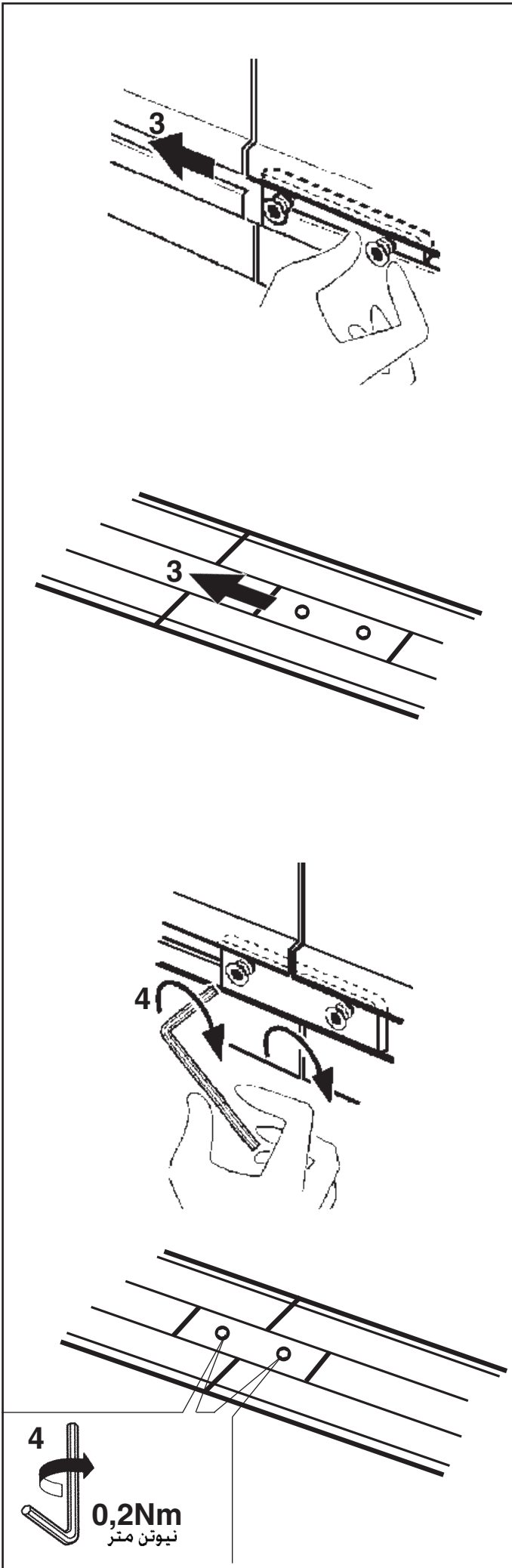

AR ضع الملصق "E" كما هو موضح في الشكل.



IT Applicare l'etichetta "E" come mostrato in figura.

EN Apply label "E" as shown in the figure.

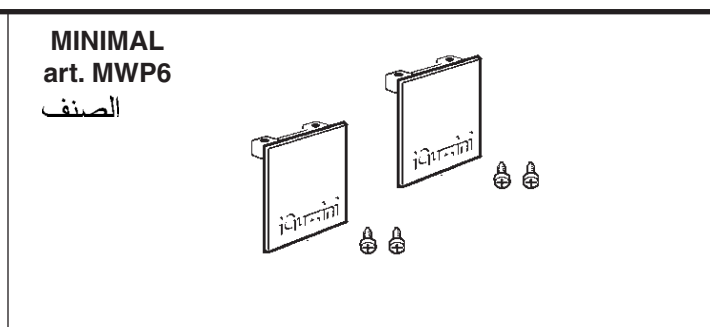
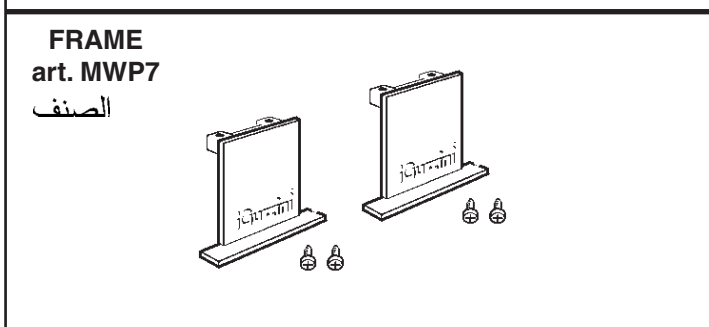
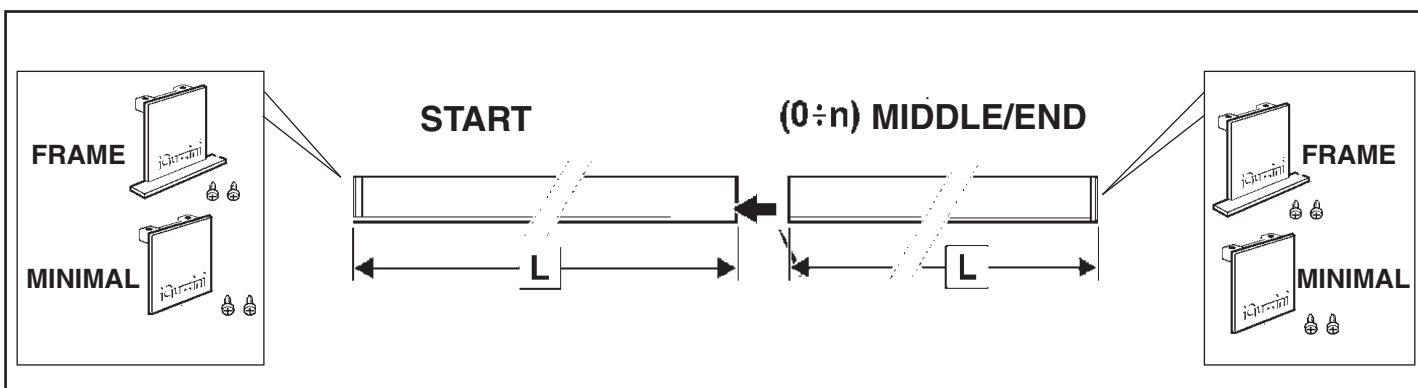

ES Aplicar la etiqueta "E" según lo ilustrado en la figura.

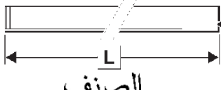
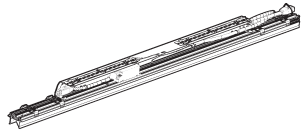

UP/ DOWN

TYPE	L (mm)	 الصف ART.	START	MIDDLE/ END	
 GENERAL LIGHTING LOW CONTRAST	1208	QA96	●		QB24 - QB26 - QB28 - QB30 - QB56 - QB58 - QB60 - QB62
	2397	QA97	●	2x	QB24 - QB26 - QB28 - QB30 - QB56 - QB58 - QB60 - QB62
	3596	QA98	●		QB25 - QB27 - QB29 - QB31 - QB57 - QB59 - QB61 - QB63
	3596	QA99		●	QB25 - QB27 - QB29 - QB31 - QB57 - QB59 - QB61 - QB63
 UGR <19°	1208	QB76	●		QC04 - QC06 - QC08 - QC10
	2397	QB77	●	2x	QC04 - QC06 - QC08 - QC10
	3596	QB78	●		QC05 - QC07 - QC09 - QC11
	3596	QB79		●	QC05 - QC07 - QC09 - QC11

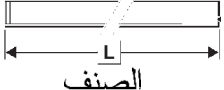
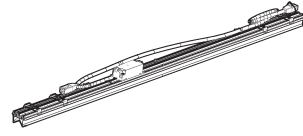
DOWN

TYPE	L (mm)	 الصف ART.	START	MIDDLE/ END	
 GENERAL LIGHTING LOW CONTRAST	612	QA84 - QA90 - QZ63 - QZ57	●		QB08 - QB12 - QB16 - QB20 - QB40 - QB44 - QB48 - QB52
	898	QA88 - QA94 - QZ67 - QZ61		●	QB09 - QB13 - QB17 - QB21 - QB41 - QB45 - QB49 - QB53
	1208	QA85 - QA91 - QZ64 - QZ58	●		QB10 - QB14 - QB18 - QB22 - QB42 - QB46 - QB50 - QB54
	2397	QA86 - QA92 - QZ65 - QZ59	●	2x	QB10 - QB14 - QB18 - QB22 - QB42 - QB46 - QB50 - QB54
	3596	QA87 - QA93 - QZ66 - QZ60	●		QB11 - QB15 - QB19 - QB23 - QB43 - QB47 - QB51 - QB55
	3596	QA89 - QA95 - QZ68 - QZ62		●	QB11 - QB15 - QB19 - QB23 - QB43 - QB47 - QB51 - QB55
 UGR <19°	612	QB64 - QB70 - QZ91 - QZ85	●		QB88 - QB92 - QB96 - QC00
	898	QB68 - QB74 - QZ95 - QZ89		●	QB89 - QB93 - QB97 - QC01
	1208	QB65 - QB71 - QZ92 - QZ86	●		QB90 - QB94 - QB98 - QC02
	2397	QB66 - QB72 - QZ93 - QZ87	●	2x	QB90 - QB94 - QB98 - QC02
	3596	QB67 - QB73 - QZ94 - QZ88	●		QB91 - QB95 - QB99 - QC03
	3596	QB69 - QB75 - QZ96 - QZ90		●	QB91 - QB95 - QB99 - QC03

EXAMPLES:

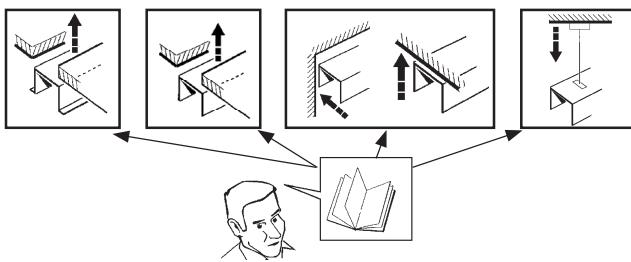
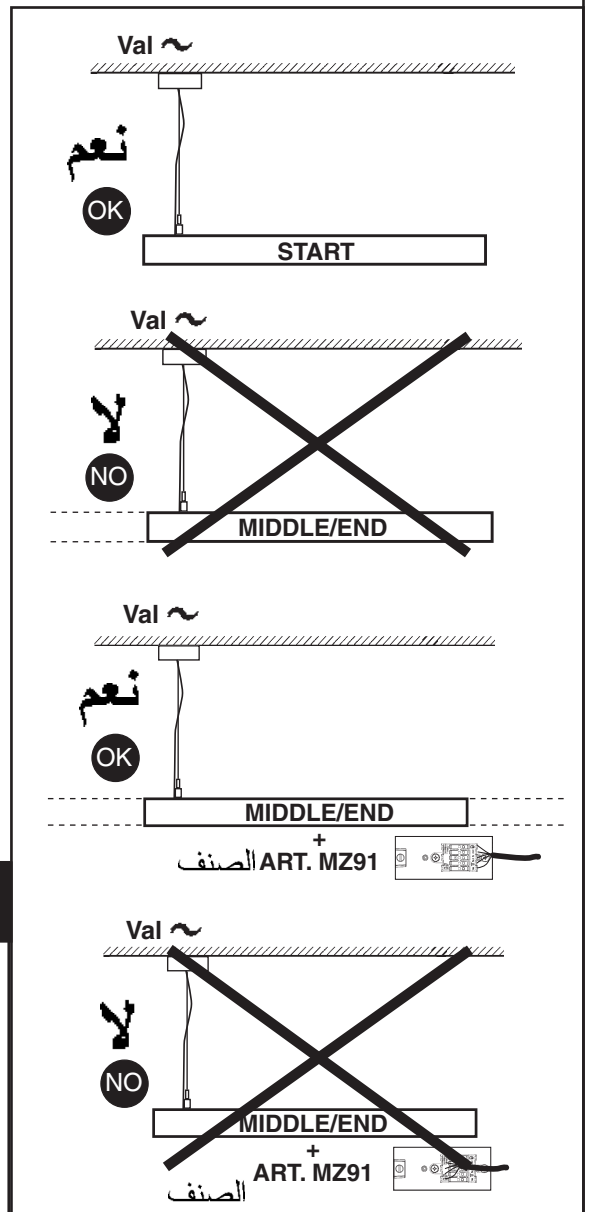
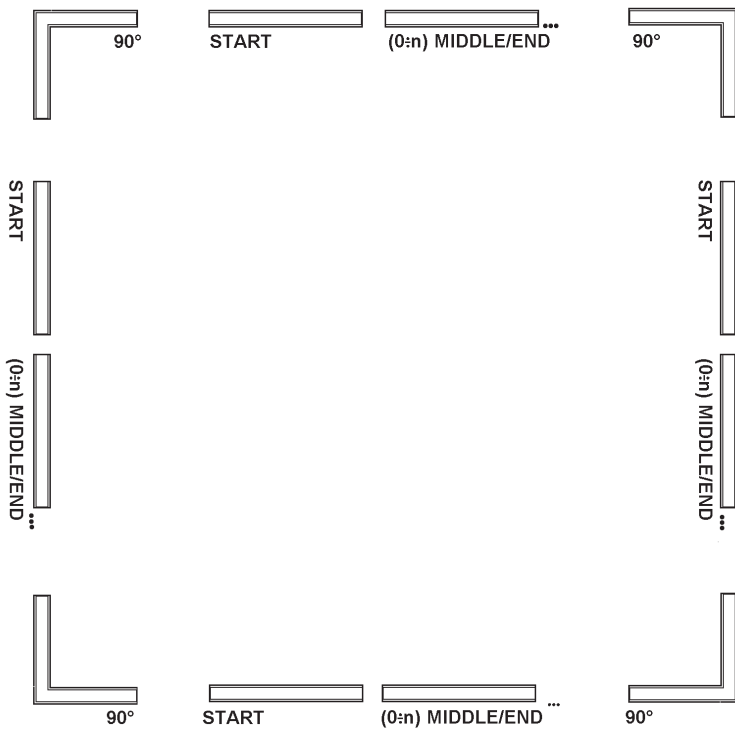
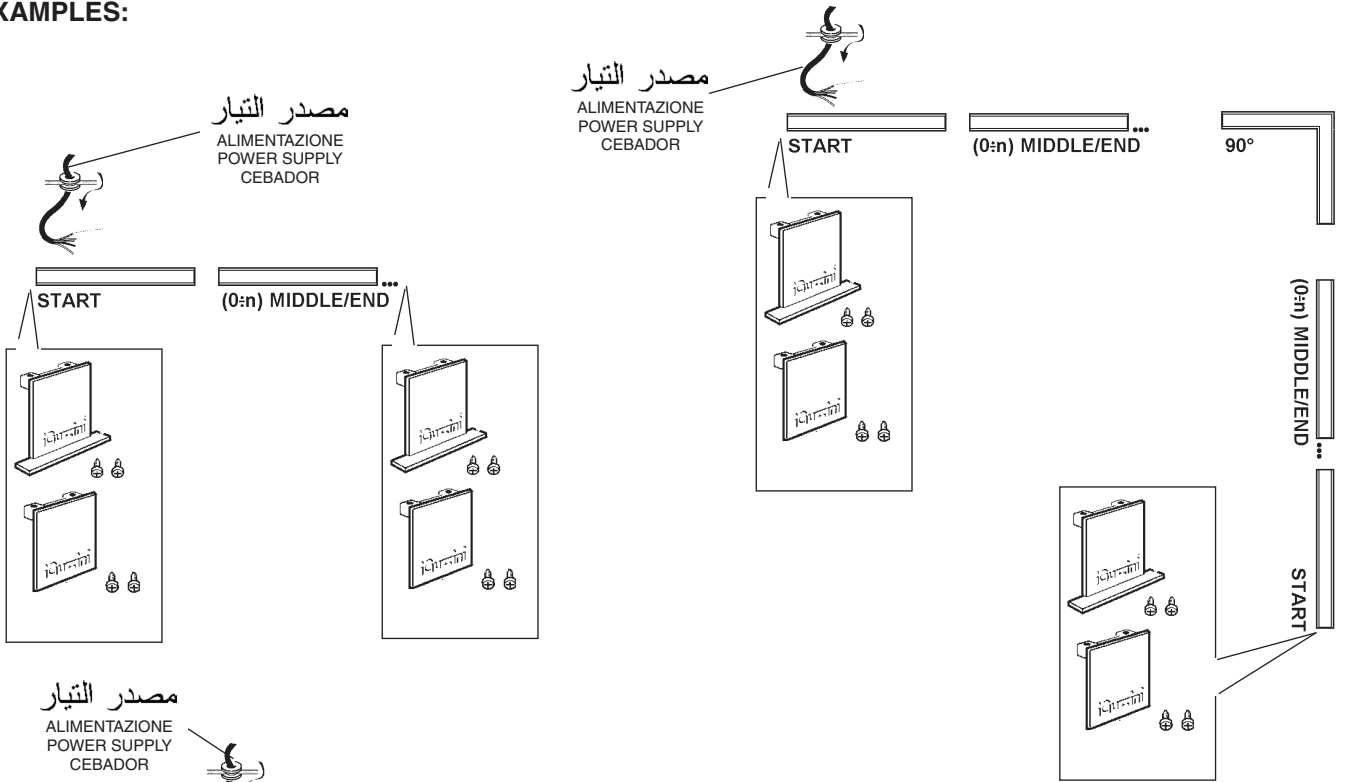

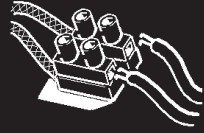

تحديد أقصى حد للتيارات المسموح بها

DETERMINAZIONE DELLE CORRENTI MASSIME AMMISSIBILI
DETERMINING THE MAXIMUM PERMITTED CURRENT
DETERMINACIÓN DE LAS CORRIENTES MÁXIMAS PERMITIDAS

AR يجب - عند تصميم جهاز الإضاءة والكهرباء - أن يتم تحديد أقصى تيارات كهربائية مسموح بها، وذلك مع أخذ العوامل التالية بعين الاعتبار:
- الحصول على التيار الكهربائي المسموح به، من خلال شرائح التوصيل المسمّاة بالرمز MAX 9A وذلك بالنسبة للكابل المراد بين الوحدات المختلفة،
- معامل الأمان، بحيث يؤخذ بعين الاعتبار الجهود الكهربائية الزائدة، وكذلك فترات التشغيل،
- الاستهلاك الاسمي الحالي لكل وحدة من الوحدات (انظر الجدول).

IT Nella progettazione dell'impianto illuminotecnico ed elettrico, determinare le correnti massime ammissibili, considerando i seguenti fattori:
- corrente nominale ammessa dalle morsettiere MAX 9A per cablaggio passante fra moduli;
- coefficiente di sicurezza per tenere conto delle sovratensioni e contemporaneità;
- corrente nominale assorbita dai singoli moduli (vedi tabella).

EN When designing the lighting and electrical systems, work out the maximum permitted current based on the following factors:
- rated current permitted by terminal blocks MAX 9 A for through wiring between modules;
- safety coefficient to allow for overvoltage and contemporaneity;
- rated current absorbed by single modules (see table).

ES Durante la proyectación de la instalación luminotécnica y eléctrica, determinar las corrientes máximas permitidas, en consideración de los factores siguientes:
- corriente nominal permitida por las clemas de conexión MAX 9A para cableado pasante entre módulos;
- coeficiente de seguridad para considerar sobretensiones y contemporaneidades;
- corriente nominal absorbida por los módulos individuales (ver tabla).

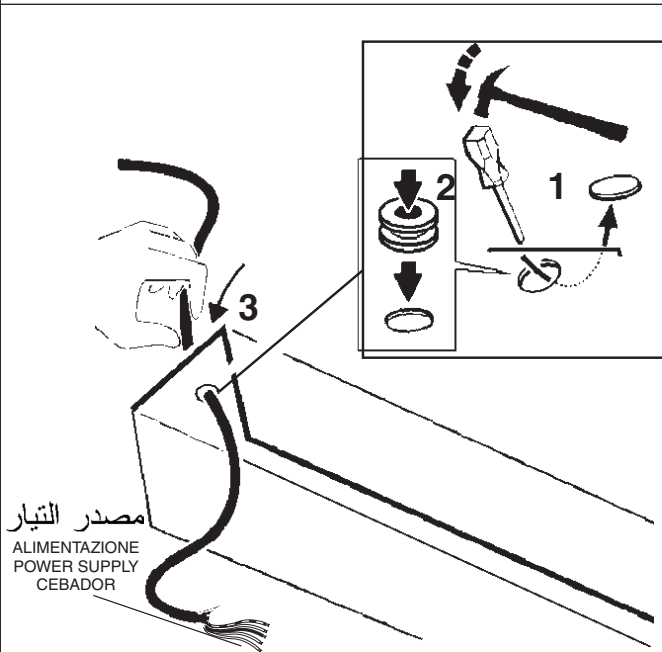

AR استخدم المكون MZ91 كلما كان هناك ضرورة لاستخدام وصلة تطويل جديدة للطاقة . (انظر جدول الحدود القصوى للتيار المسموح بها).

IT Utilizzare l'art. MZ91 ogni qual volta è necessario effettuare una nuova calata di alimentazione (vedere tabella delle correnti massime ammissibili.)

EN Use item MZ91 whenever it is necessary to effect a new power extension. (see maximum tolerable currents table)

ES Utilizar el art. MZ91 cada vez que se necesite efectuar una nueva alimentación intermedia (véase la tabla de corrientes máximas permitidas)

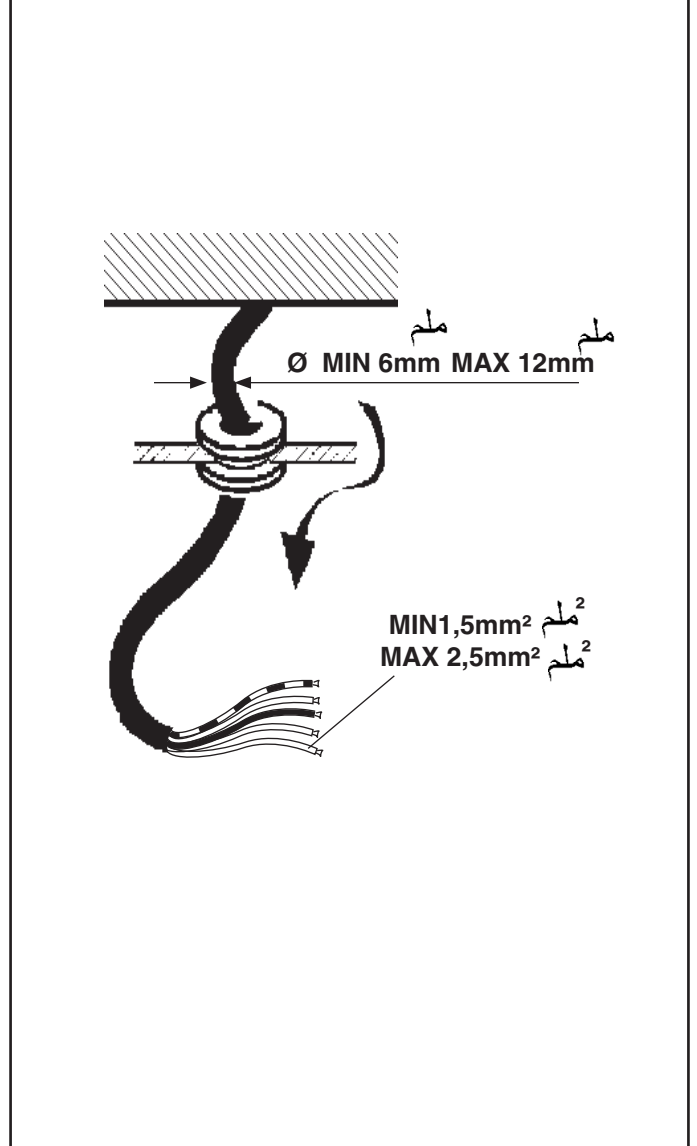
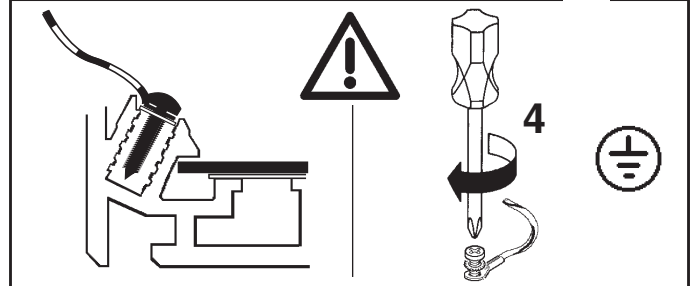
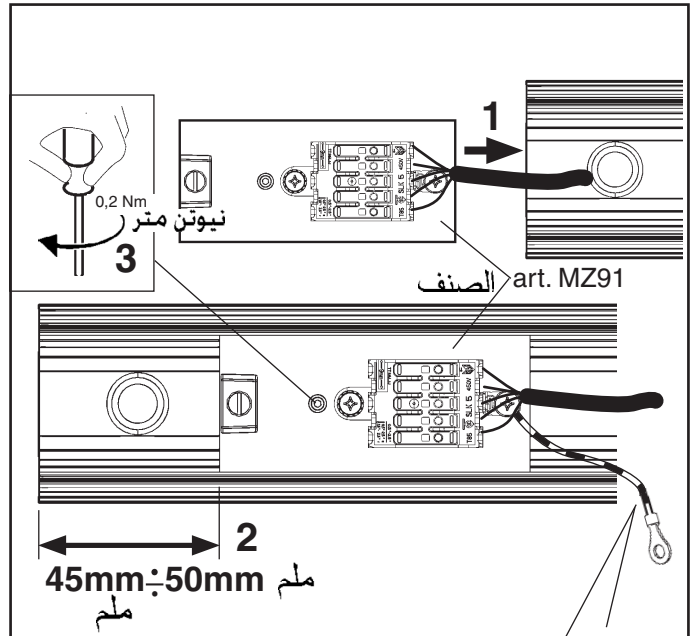

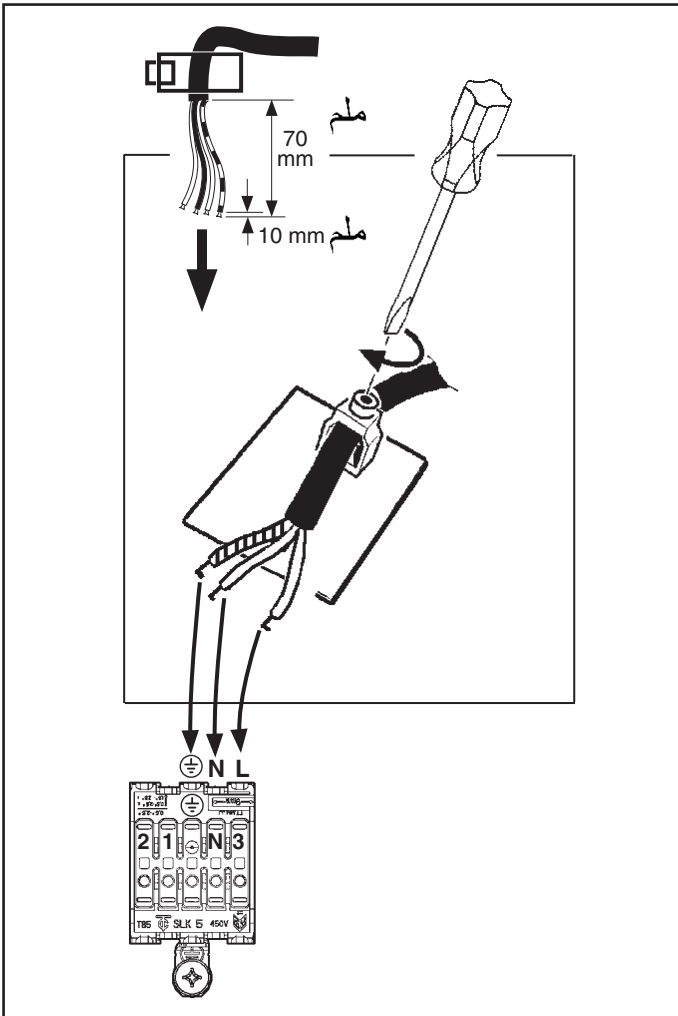

DALI

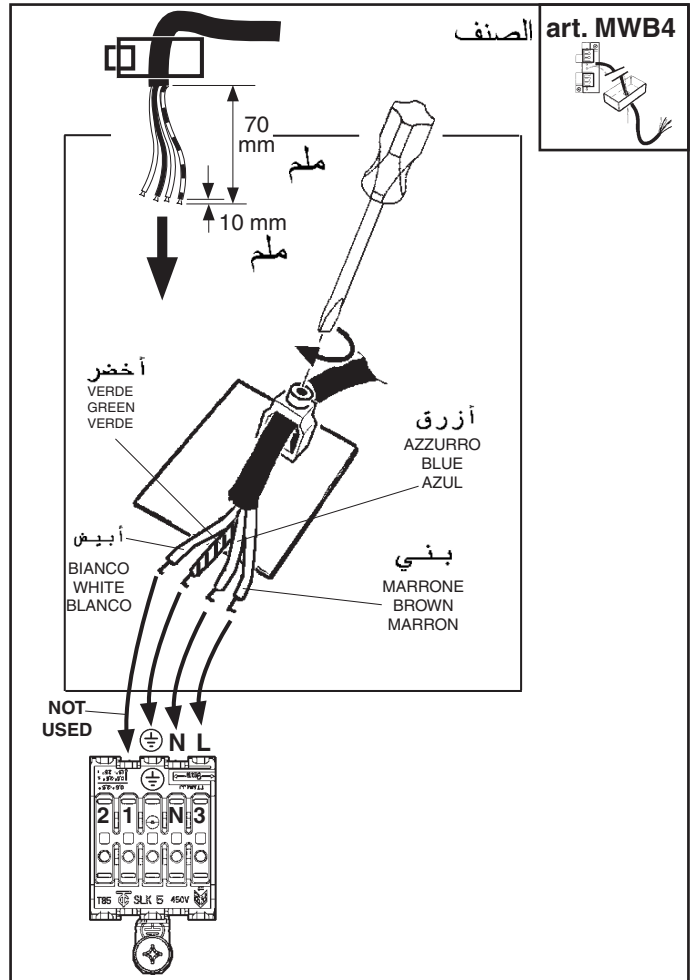
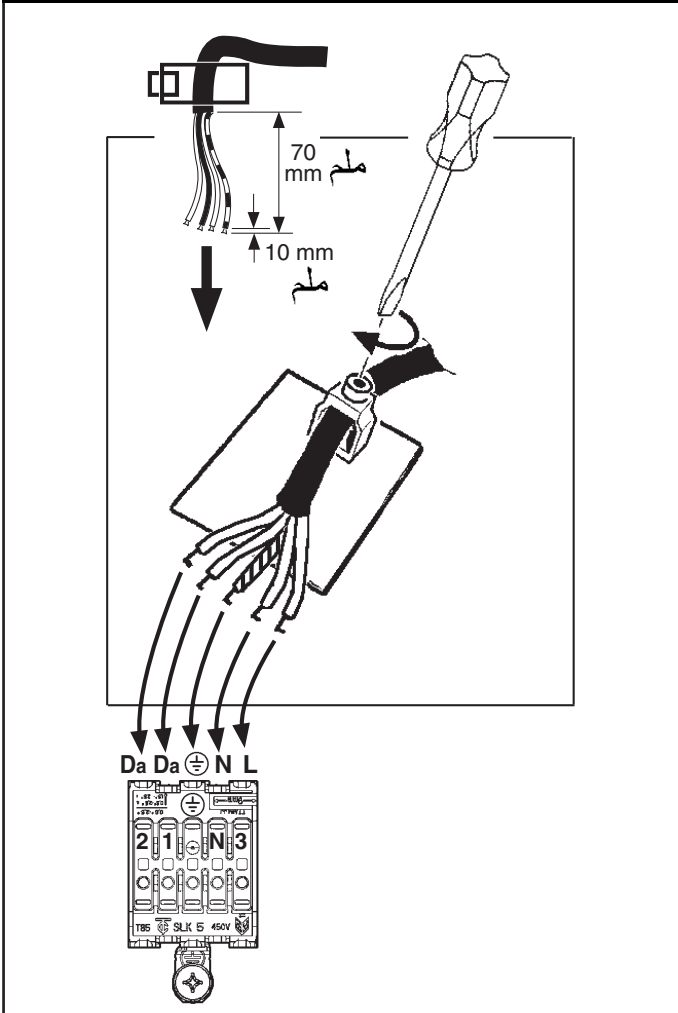

DALI

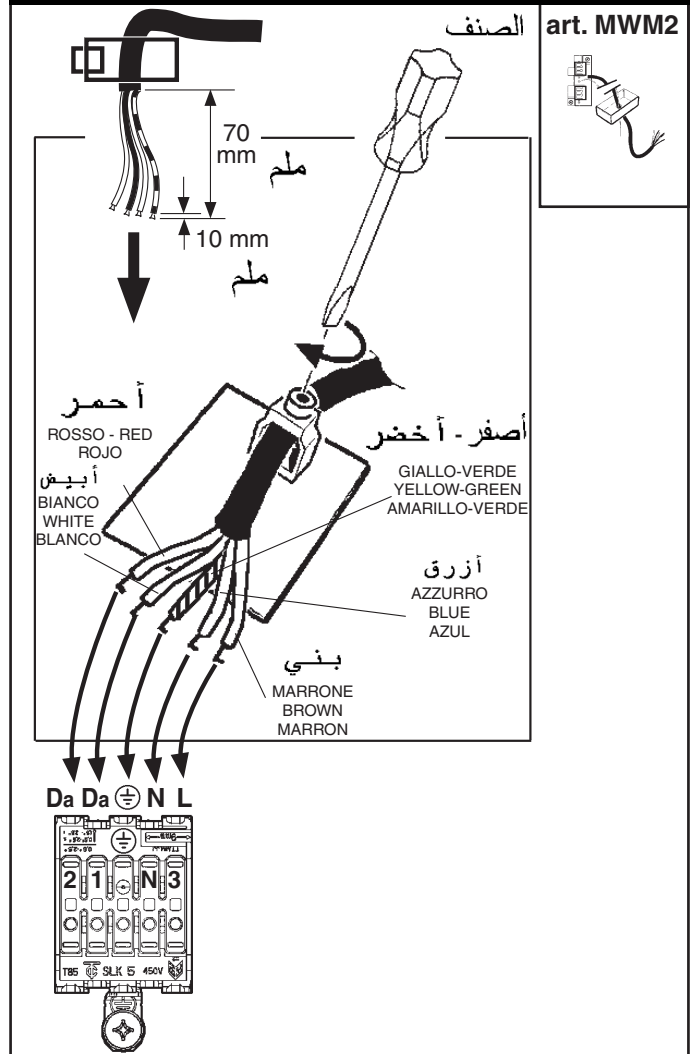

TOUCH DIM

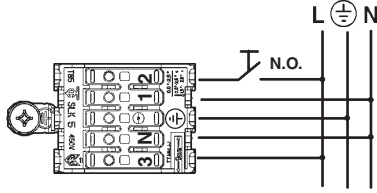

AR يمكن أن يتم تخفيض إضاءة الأجهزة ذات الكابلات الرقمية؛ وذلك عن طريق استخدام أجهزة الإمداد بالطاقة الكهربائية "دالي" (DALI)، أو عن طريق استخدام زر يكون مفتوحًا في وضعه الطبيعي (N.O.)؛ حيث يتم التوصيل كما هو مبين في المخطط.

IT I dispositivi con cablaggio digitale possono essere dimmerati con dispositivi DALI o con pulsante normalmente aperto (N.O.) da collegare come da schema.

EN Devices with digital control gear may be dimmed using DALI devices or a normally-open button (N.O.) to be connected as shown in the diagram.

ES Los dispositivos con cableado digital pueden regularse con dispositivos DALI o con un interruptor de botón normalmente abierto (N.O.) que se conecta según ilustrado en el esquema.

AR يمكن أن يتسبب التحكم في منتجات "دالي" المختلفة عن طريق الأزرار، (مثل الأزرار: "تفتش - ديم"، "سويتش - ديم"، "بوش - ديم"، دايركت - ديم"، إلخ.)، في حدوث مشاكل تتعلق بعملية التزامن بين هذه الأزرار. وإن كان من الممكن تجنب مثل هذه المشاكل، وذلك عن طريق تزويد بعض الأجهزة الإضافية، ندعوكم للاتصال المباشر بالشركة؛ وذلك للحصول على أكبر قدر من المعلومات.

IT Pilotare diversi prodotti DALI tramite pulsante (es: Touch-dim, Switch-dim, Push-dim, Direct-dim, etc.) potrebbe causare dei problemi di sincronizzazione tra gli stessi. È possibile ovviare a questo problema dotandosi di dispositivi aggiuntivi. Per maggiori informazioni vi invitiamo a contattarci direttamente.

EN Controlling different DALI products through buttons (e.g.: Touch-dim, Switch-dim, Push-dim, Direct-dim, etc.) may lead to product synchronisation problems. This problem can be overcome by using additional devices. For further information, please contact us directly.

ES El mando de varios productos DALI por tecla (ej: Touch-dim, Switch-dim, Push-dim, Direct-dim, etc.) podría causar problemas de sincronización entre ellos. Es posible prevenir este problema utilizando dispositivos adicionales. Para más información, contacte directamente con nosotros.

EXAMPLE:

START

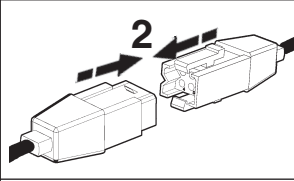
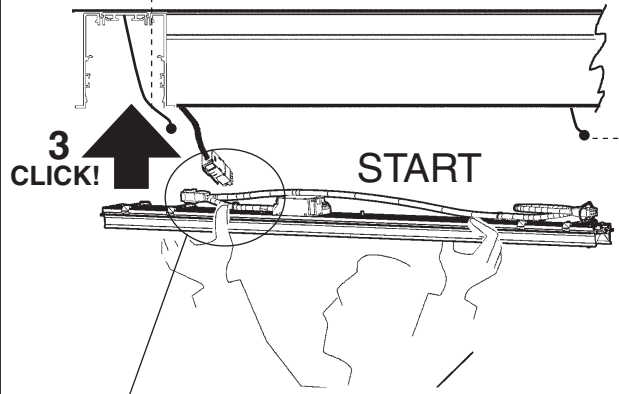
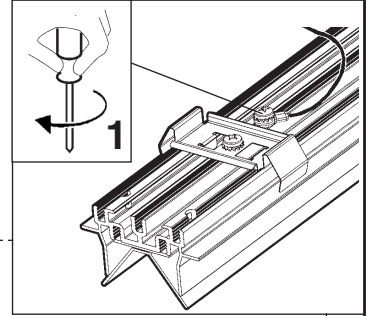

شحنة DALI / حمل
CARICO DALI / DALI LOAD
CHARGE DALI
CARGA DALI

عناوين DALI
INDIRIZZI DALI
DALI ADDRESSES
DIRECCIONES DALI

1 (2 mA)

1

ART. QB57-QB59-QB61-QB63 2 (4 mA)

2

الصنف ART. QB13-QB21-QB44-QB52-QB88-QB92-QB96-QC00

AR لا يجب تعديل بارامترات الطاقة الكهربائية الخاصة بالنظام "دالي"؛ والتي تم إعدادها من قِبل مؤسسة "إيجوزيني"

IT NON MODIFICARE I PARAMETRI DELL'ALIMENTATORE DALI IMPOSTATI DALLA "iGuzzini"

EN DO NOT CHANGE THE DALI POWER-UNIT PARAMETERS SET BY "iGuzzini"

ES NO CAMBIAR LOS PARÁMETROS DEL ALIMENTADOR DALI PROGRAMADOS POR "iGuzzini"

EXAMPLE:

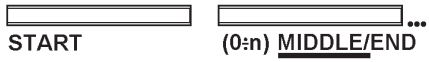

START/ MIDDLE

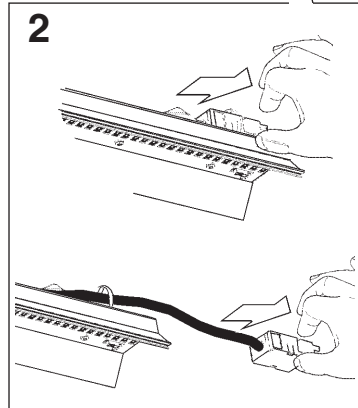
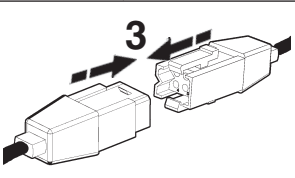
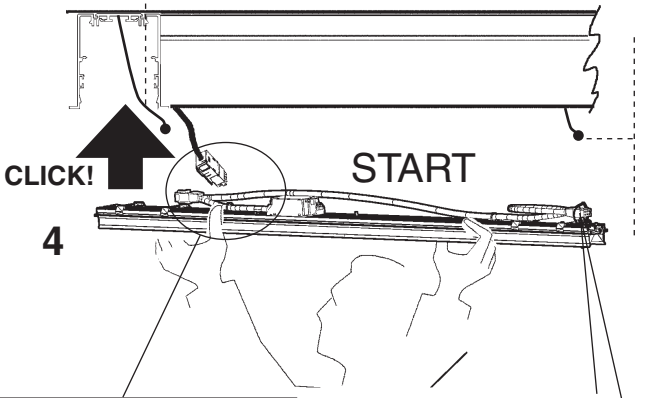
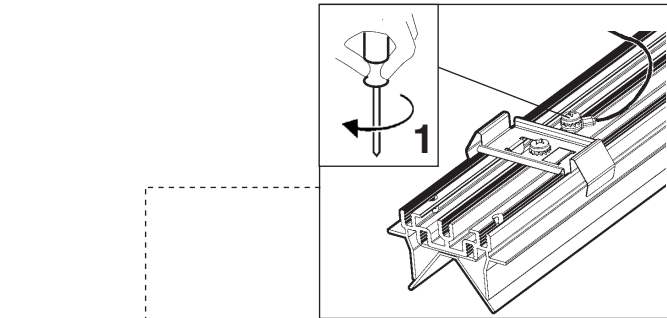

EXAMPLE:



END

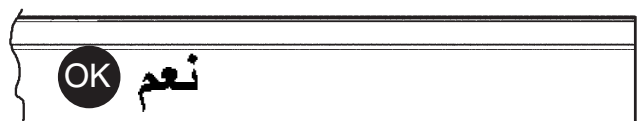
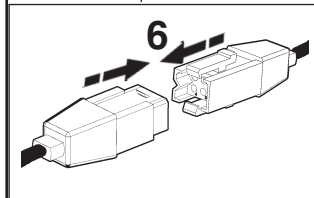
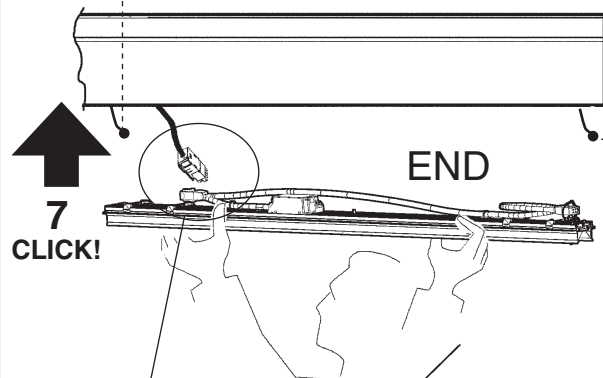
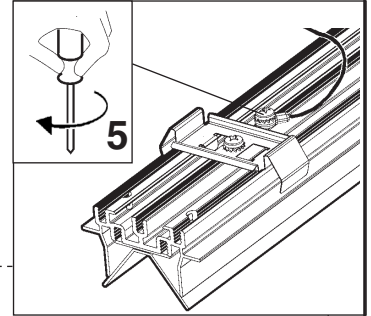

EXAMPLE:

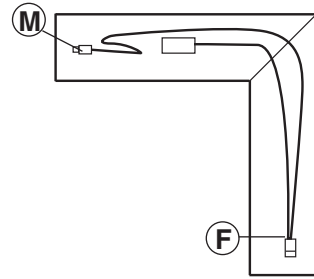
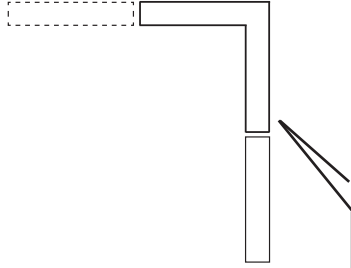
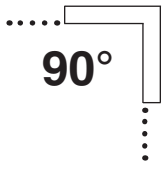

EXAMPLE:

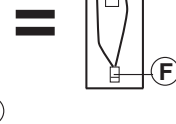
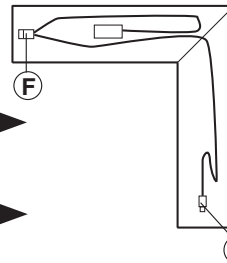
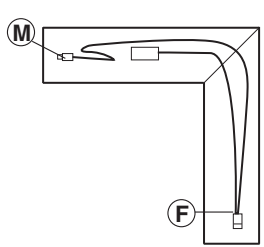
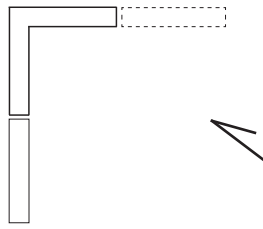
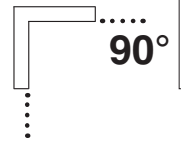

M

مذكر
Maschio
Male
Macho

F

مؤنث
Femmina
Female
Hembra

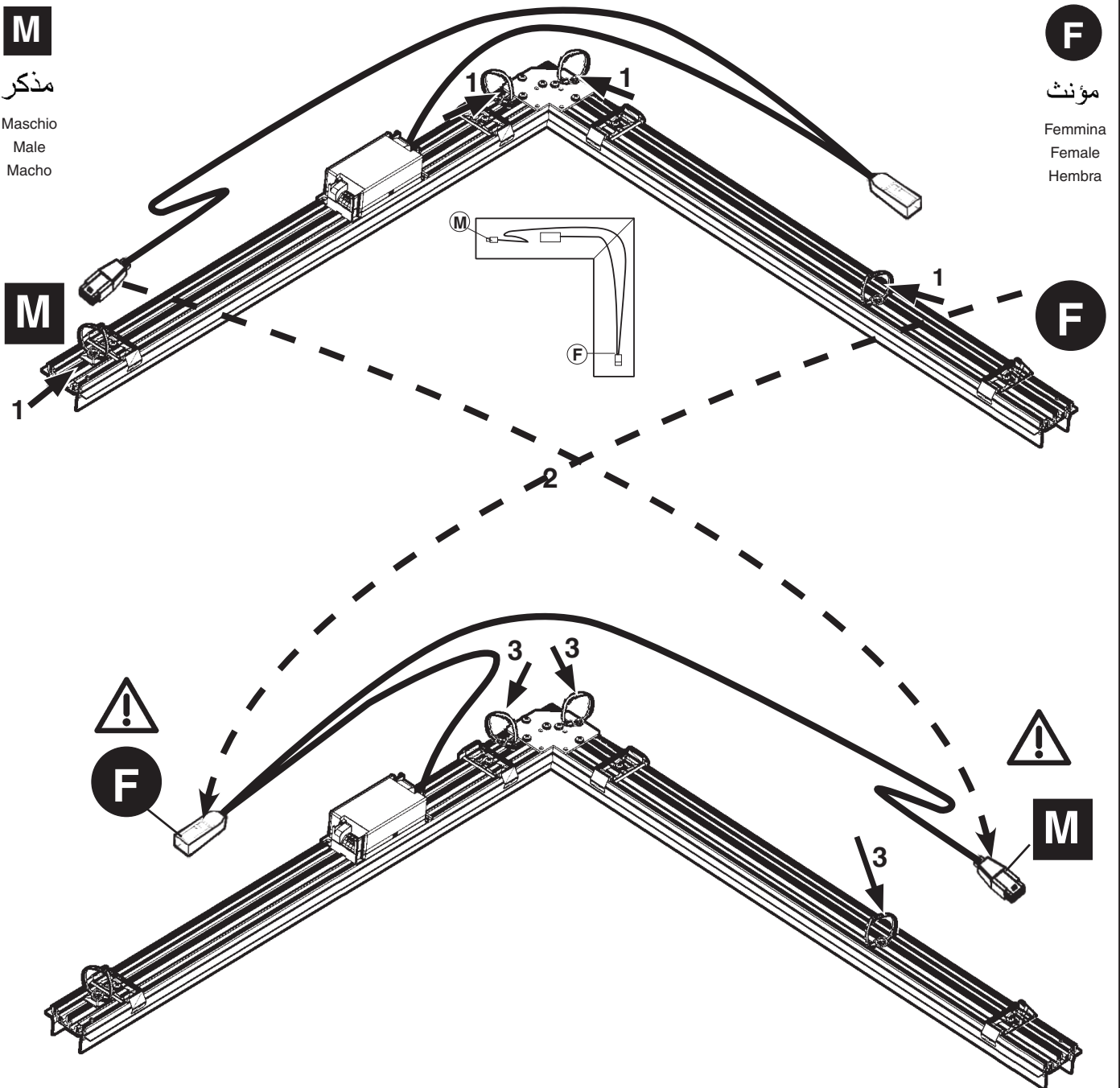

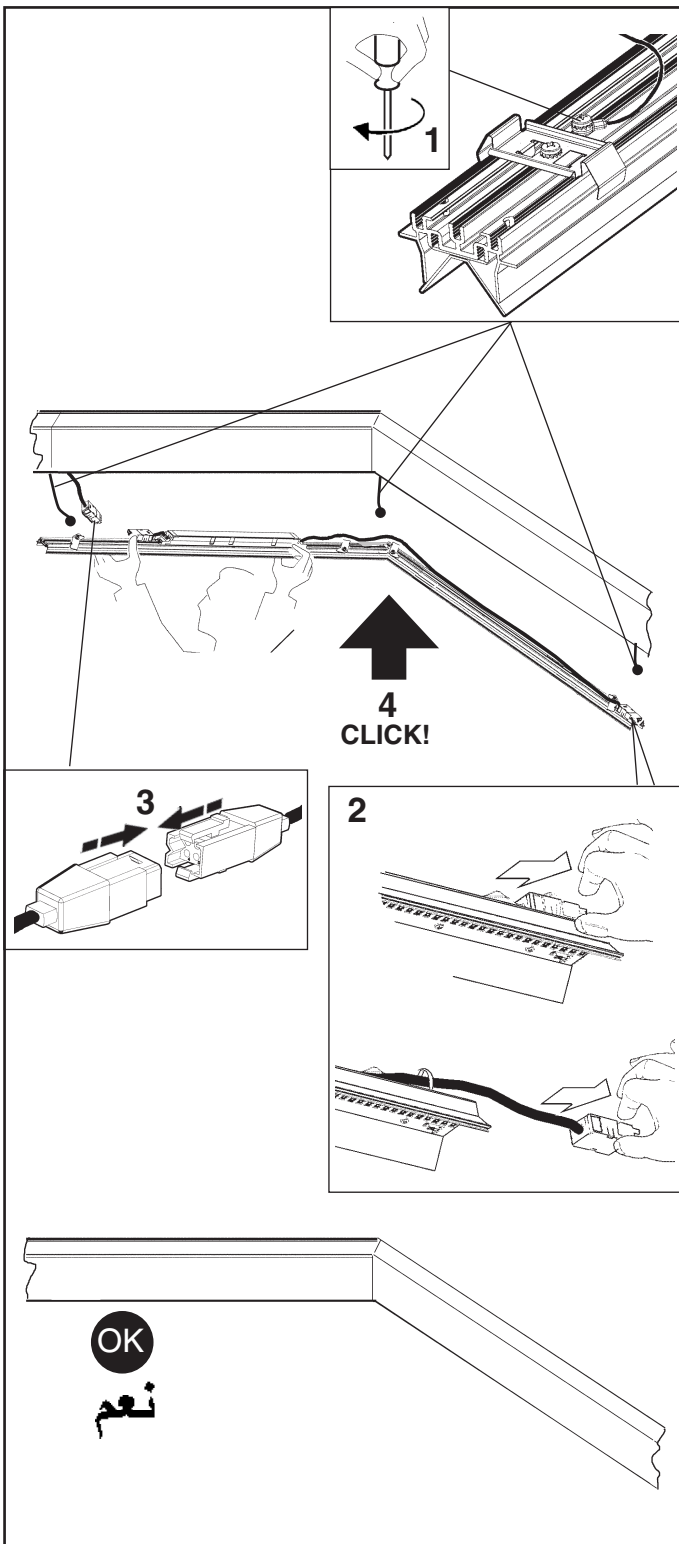
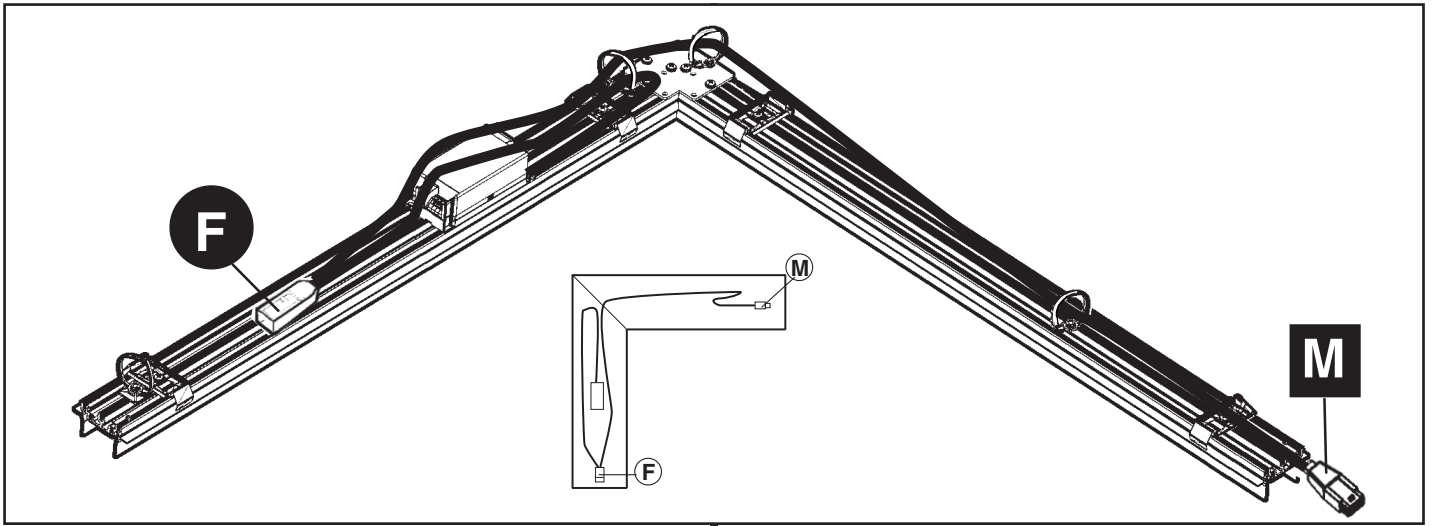

10

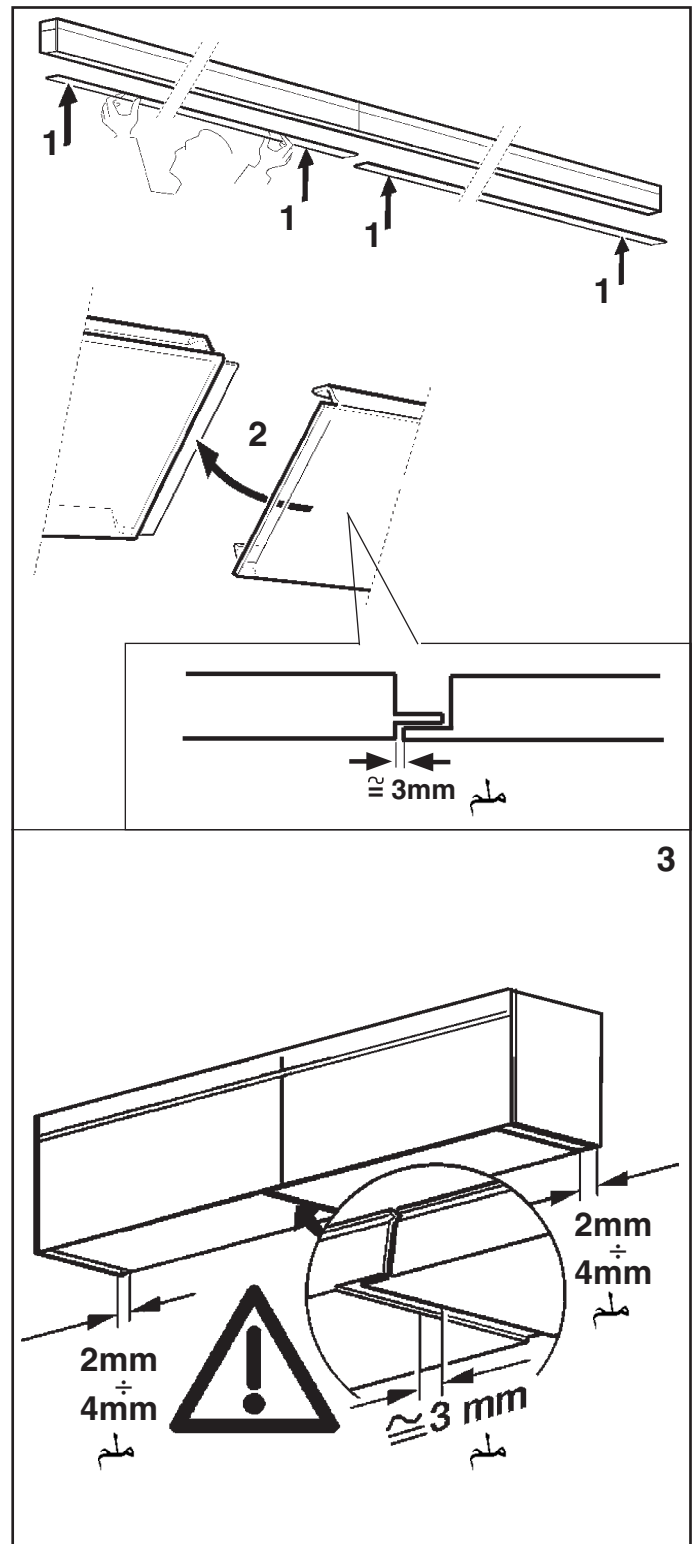

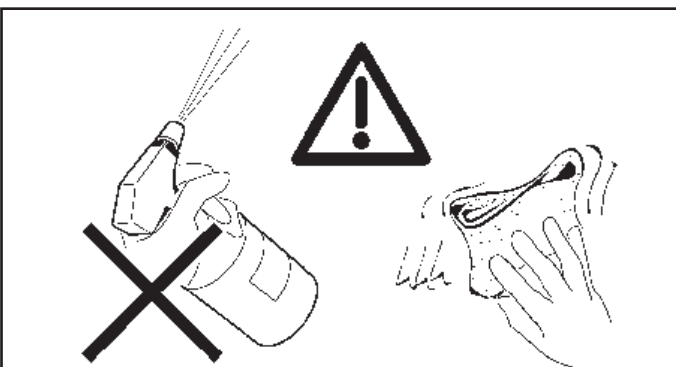
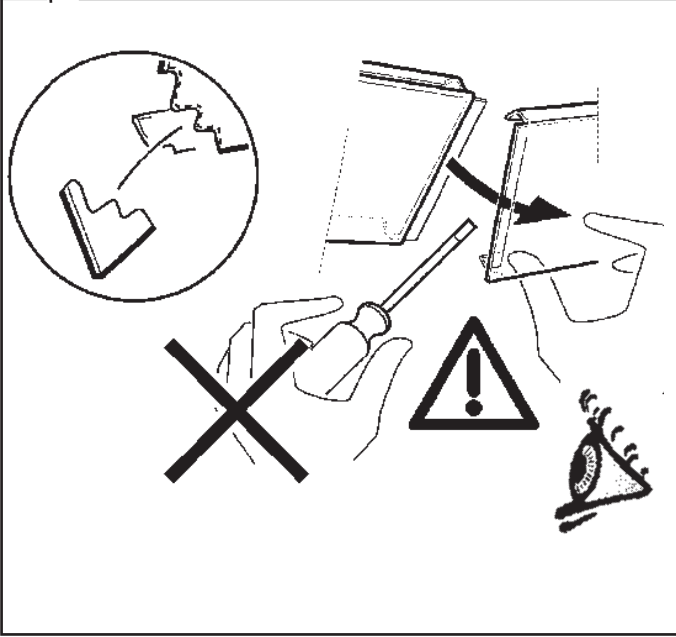
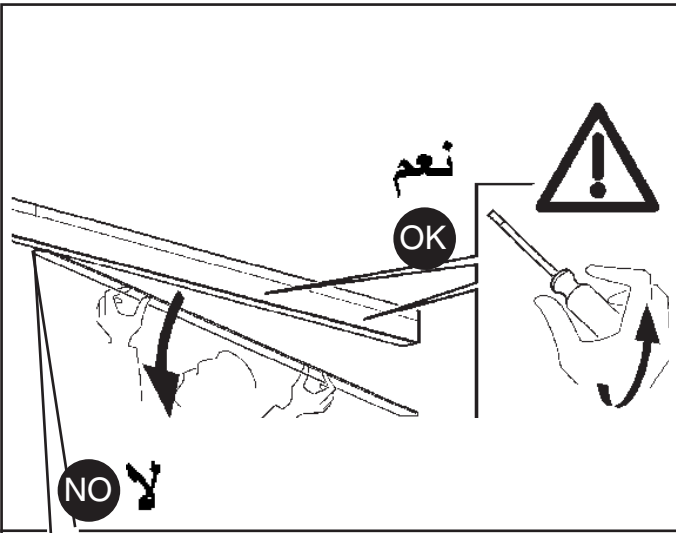

AR ملاحظة: إذا كان العاكس بحاجة إلى تنظيف لا تستعمل الماء أو المنظفات واستخدم قطع قماش ناعمة وجافة فقط.

IT N.B.: Per l'eventuale pulizia non utilizzare acqua o solventi vari, usare esclusivamente panni morbidi asciutti.

EN N.B.: When cleaning, do not use water or any type of solvent. Use only soft dry cloths.

ES NOTA: Para la limpieza eventual no usar agua ni solventes de cualquier género, sino exclusivamente un pano suave y seco.

AR في ما يتعلق بأوضاع التركيب، التزم بما هو موضح ومحدد، إذا دعت الضرورة اتصل بـ iGuzzini

IT Per le posizioni di installazione, attenersi a quelle illustrate, eventualmente contattare la iGuzzini.

EN All installation positions must comply with those illustrated. In the event of any doubt, contact iGuzzini.

ES Respetar las posiciones de instalación ilustradas y, en caso de duda, contactar con iGuzzini

AR تنبيه: لاستبدال الضوء LED اتصل بشركة iGuzzini

IT N.B.: Per la sostituzione del LED contattare l'azienda iGuzzini.

EN N.B.: For information on LED replacement please contact iGuzzini.

ES NOTA: Para sustituir el LED llame a la empresa iGuzzini.

1.154.072.01 IS12594/01	iGuzzini	fattore di potenza power factor facteur de puissance Leistungsfaktor vermogensfactor factor de potencia effektfaktor effektfaktor effektfaktor фактор мощности 功率因数	corrente assorbita absorbed current courant absorbé Stromaufnahme stromopname corriente absorbida absorberet strøm absorbert strøm tillförd ström поглощаемая мощность 电源电流
ART.	λ	A	A
QB08 - QB16	>0,9	0,04	
QB09 - QB17	>0,9	0,06	
QB10 - QB18 - QB00 - QB02 - QB04 - QB06 - QZ77 - QZ78 QZ69 - QZ70	>0,95	0,07	
QB11 - QB19	>0,95	0,21	
QB12 - QB20	>0,9	0,04	
QB13 - QB21	>0,9	0,06	
QB14 - QB22 - QB01 - QB03 - QB05 - QB07 - QZ79 - QZ80 QZ71 - QZ72	>0,95	0,07	
QB15 - QB23	>0,95	0,22	
QB24 - QB28	>0,95	0,1	
QB25 - QB29	>0,95	0,35	
QB26 - QB30	>0,95	0,11	
QB27 - QB31	>0,95	0,33	
QB40 - QB48	>0,9	0,06	
QB41 - QB49	>0,95	0,08	
QB42 - QB50 - QB32 - QB34 - QB36 - QB38 - QZ81 - QZ82 QZ73 - QZ74	>0,95	0,11	
QB43 - QB51	>0,95	0,33	
QB44 - QB52	>0,9	0,06	
QB45 - QB53	>0,95	0,08	
QB46 - QB54 - QB33 - QB35 - QB37 - QB39 - QZ83 - QZ84 QZ75 - QZ76	>0,95	0,11	
QB47 - QB55	>0,95	0,33	
QB56 - QB60	>0,95	0,16	
QB57 - QB61	>0,95	0,51	
QB58 - QB62	>0,95	0,15	
QB59 - QB63	>0,95	0,2	
QB88 - QB96	>0,8	0,03	
QB89 - QB97	>0,9	0,04	
QB90 - QB98 - QB80 - QB82 - QB84 - QB86 - R051 - R052 QZ98 - QZ97	>0,9	0,05	
QB91 - QB99	>0,95	0,13	
QB92 - QC00	>0,8	0,03	
QB93 - QC01	>0,9	0,04	
QB94 - QC02 - QB81 - QB83 - QB85 - QB87 - R053 - R054 QZ99 - R050	>0,9	0,05	
QB95 - QC03	>0,95	0,13	
QC04 - QC08	>0,95	0,07	
QC05 - QC09	>0,95	0,19	
QC06 - QC10	>0,9	0,06	
QC07 - QC11	>0,95	0,19	

1.154.072.01 IS12594/01	iGuzzini	fattore di potenza power factor facteur de puissance Leistungsfaktor vermogensfactor factor de potencia effektfaktor effektfaktor effektfaktor фактор мощности 功率因数	corrente assorbita absorbed current courant absorbé Stromaufnahme stromopname corriente absorbida absorberet strøm absorbert strøm tillförd ström поглощаемая мощность 电源电流
ART.	λ	A	A
QB08 - QB16	>0,9	0,04	
QB09 - QB17	>0,9	0,06	
QB10 - QB18 - QB00 - QB02 - QB04 - QB06 - QZ77 - QZ78 QZ69 - QZ70	>0,95	0,07	
QB11 - QB19	>0,95	0,21	
QB12 - QB20	>0,9	0,04	
QB13 - QB21	>0,9	0,06	
QB14 - QB22 - QB01 - QB03 - QB05 - QB07 - QZ79 - QZ80 QZ71 - QZ72	>0,95	0,07	
QB15 - QB23	>0,95	0,22	
QB24 - QB28	>0,95	0,1	
QB25 - QB29	>0,95	0,35	
QB26 - QB30	>0,95	0,11	
QB27 - QB31	>0,95	0,33	
QB40 - QB48	>0,9	0,06	
QB41 - QB49	>0,95	0,08	
QB42 - QB50 - QB32 - QB34 - QB36 - QB38 - QZ81 - QZ82 QZ73 - QZ74	>0,95	0,11	
QB43 - QB51	>0,95	0,33	
QB44 - QB52	>0,9	0,06	
QB45 - QB53	>0,95	0,08	
QB46 - QB54 - QB33 - QB35 - QB37 - QB39 - QZ83 - QZ84 QZ75 - QZ76	>0,95	0,11	
QB47 - QB55	>0,95	0,33	
QB56 - QB60	>0,95	0,16	
QB57 - QB61	>0,95	0,51	
QB58 - QB62	>0,95	0,15	
QB59 - QB63	>0,95	0,2	
QB88 - QB96	>0,8	0,03	
QB89 - QB97	>0,9	0,04	
QB90 - QB98 - QB80 - QB82 - QB84 - QB86 - R051 - R052 QZ98 - QZ97	>0,9	0,05	
QB91 - QB99	>0,95	0,13	
QB92 - QC00	>0,8	0,03	
QB93 - QC01	>0,9	0,04	
QB94 - QC02 - QB81 - QB83 - QB85 - QB87 - R053 - R054 QZ99 - R050	>0,9	0,05	
QB95 - QC03	>0,95	0,13	
QC04 - QC08	>0,95	0,07	
QC05 - QC09	>0,95	0,19	
QC06 - QC10	>0,9	0,06	
QC07 - QC11	>0,95	0,19	